



2018



# Sommario

---

# Summary

---

<u>TENDENZA</u>	21	<u>ACCIAIO</u>	73	<u>THIN</u>	89	<u>TRADIZIONALI</u>	123
TREND		STAINLESS STEEL		THIN		TRADITIONAL	
BLADE	22	STRAIGHT	74	RAKE	90	EXPRESS	124
EIDOS	24	KUBE	76	OPERA2	92	METRO	126
JAM	26	ALFA	77	BLADE QT	94	METRO ROUND	128
TUKE	28	BETA	78	EIDOS QT	96	ATON	130
TUKE GLASS	30	CHRISTINA	79	TUKE QT	98	BUTTERFLY	132
SHARP	32	LOREDANA	80	JAM QT	100	VENERE	134
SWEEP	34	LOREDANA SQUARE	81	JOIN	102	SOFT	136
INNER	36	ADINA	82	IBIS	104	SOFT PLUS	138
LEAF	38	ALESSIA	83	PAVONE	106	NICOLE	140
ICE Q	40	LOFT	84	FENICE	108	NICOLE PLUS	142
ICE PLUS	42	LUCIA	85	FILOO	110	LAGUNA	144
SLIM	43	LUCIA SQUARE	86	BUMP	112	EURO	146
FLOW	44			DUCK	114	UOVO	148
FLOW ROUND	46			KUMA RT	116	APOLLO	150
ARIA	48			KALÈ QT	117	STAR	152
ARIA ROUND	50			SWEEP QT	118	MODULO L	154
KUMA	52			UOVO RT	119	EASY	156
PINAX	54			LEAF RT	120	HALLEY	158
KALÈ	56					300/LP	160
MODULO Q	58					300/LE	161
JOUR	60					RAFFAELLA	162
CHIC	62					LAURA	163
QUEEN	64					MIMOSA	164
NUIT	66						
KING	68						
POMOLINI	70						
						KIT PORTE	167
						SCORREVOLI, POMOLI	
						E ACCESSORI	
						SLIDING DOOR HANDLES, PULL	
						HANDLES & ACCESSORIES	

# Indice

---

ADINA	82	KUBE	76	TUKE QT	98
ALESSIA	83	KUMA	52	UOVO	148
ALFA	77	KUMA RT	116	UOVO RT	119
APOLLO	150	LAGUNA	144	VENERE	134
ARIA	48	LAURA	163	300/LE	161
ARIA ROUND	50	LEAF	38	300/LP	160
ATON	130	LEAF RT	120		
BETA	78	LOFT	84		
BLADE	22	LOREDANA	80		
BLADE QT	94	LOREDANA SQUARE	81		
BUMP	112	LUCIA	85		
BUTTERFLY	132	LUCIA SQUARE	86		
CHIC	62	METRO	126		
CHRISTINA	79	METRO ROUND	128		
DUCK	114	MIMOSA	164		
EASY	156	MODULO L	154		
EIDOS	24	MODULO Q	58		
EIDOS QT	96	NICOLE	140		
EURO	146	NICOLE PLUS	142		
EXPRESS	124	NUIT	66		
FENICE	108	OPERA2	92		
FILOO	110	PAVONE	106		
FLOW	44	PINAX	54		
FLOW ROUND	46	QUEEN	64		
HALLEY	158	RAFFAELLA	162		
IBIS	104	RAKE	90		
ICE PLUS	42	SHARP	32		
ICE Q	40	SLIM	43		
INNER	36	SOFT	136		
JAM	26	SOFT PLUS	138		
JAM QT	100	STAR	152		
JOIN	102	STRAIGHT	74		
JOUR	60	SWEEP	34		
KALÈ	56	SWEEP QT	118		
KALÈ QT	117	TUKE	28		
KING	68	TUKE GLASS	30		

# Index

---

# Finiture

---

# Finishes

---

---

## ITALIANO

<b>ACC</b>	ACCIAIO LUCIDO
<b>ACC SAT</b>	ACCIAIO SATINATO
<b>ACC SAT/CR</b>	ACCIAIO SATINATO / CROMO LUCIDO
<b>ACC SAT/ CR SAT</b>	ACCIAIO SATINATO / CROMO SATINATO
<b>ANT</b>	ANTICO
<b>ANT OPACO</b>	ANTICO OPACO
<b>ANTC</b>	ANTICATO
<b>ANTRACITE</b>	ANTRACITE
<b>BI</b>	BLACK IRON
<b>BIANCO</b>	BIANCO
<b>BICOLORE</b>	ACCIAIO BICOLORE
<b>NERO OPACO</b>	NERO OPACO
<b>BR</b>	BRONZO
<b>BT</b>	BRONZO TREND
<b>CR</b>	CROMO LUCIDO
<b>CR/ACC SAT</b>	CROMO LUCIDO / ACCIAIO SATINATO
<b>CR SAT</b>	CROMO SATINATO
<b>CR SAT/ACC</b>	CROMO SATINATO / ACCIAIO LUCIDO
<b>CR SAT/CR</b>	CROMO SATINATO / CROMO LUCIDO
<b>FS</b>	FINITURE SPECIALI*
<b>GR</b>	GREY STONE
<b>IB</b>	INOX BRASS
<b>IC</b>	INOX CHROME
<b>LNL</b>	LONDON NIGHT LUCIDO
<b>LNS</b>	LONDON NIGHT SATINATO
<b>NICK SAT</b>	NICKEL SATINATO VERNICIATO
<b>NICK SAT/NICK</b>	NICKEL SATINATO VERNICIATO / NICKEL
<b>OLV</b>	OTTONE LUCIDO VERNICIATO
<b>OSV</b>	OTTONE SATINATO VERNICIATO
<b>PERLA/CR</b>	PERLA / CROMO LUCIDO
<b>RCL</b>	RED COPPER LUCIDO
<b>RCS</b>	RED COPPER SATINATO
<b>BI-INOX</b>	BI-INOX

---

### \* FS - FINITURE SPECIALI

**NERO OPACO**  
**CORTEN**  
**CRACKLÉ**  
**LEATHER**  
**OSSIDATO**

---

## ENGLISH

<b>PSS</b>	POLISH STAINLESS STEEL
<b>SSS</b>	SATIN STAINLESS STEEL
<b>SSS/PC</b>	SATIN STAINLESS STEEL / POLISHED CHROME
<b>SSS/SC</b>	SATIN STAINLESS STEEL / SATIN CHROME
<b>AB</b>	ANTIQUÉ BRASS
<b>MAB</b>	MATT ANTIQUÉ BRASS
<b>ANTC</b>	ANTICATO (DISTRESSED FINISH)
<b>ANTRACITE</b>	ANTRACITE
<b>BI</b>	BLACK IRON
<b>WHITE</b>	WHITE
<b>BICOLOUR</b>	BICOLOUR STAINLESS STEEL
<b>BLACK MATT</b>	BLACK MATT
<b>BR</b>	BRONZE
<b>BT</b>	BRONZE TREND
<b>PC</b>	POLISHED CHROME
<b>PC/SSS</b>	POLISHED CHROME / SATIN STAINLESS STEEL
<b>SC</b>	SATIN CHROME
<b>SC/PSS</b>	SATIN CHROME / POLISHED STAINLESS STEEL
<b>SC/PC</b>	SATIN CHROME / POLISHED CHROME
<b>FS</b>	SPECIAL FINISHES*
<b>GR</b>	GREY STONE
<b>IB</b>	INOX BRASS
<b>IC</b>	INOX CHROME
<b>LNL</b>	LONDON NIGHT POLISH
<b>LNS</b>	LONDON NIGHT SATIN
<b>SN</b>	SATIN NICKEL
<b>SN/PN</b>	SATIN NICKEL / NICKEL
<b>PB</b>	POLISHED BRASS
<b>SB</b>	SATIN BRASS
<b>P/PC</b>	PEARL / POLISHED CHROME
<b>RCL</b>	RED COPPER POLISHED
<b>RCS</b>	RED COPPER SATIN
<b>BI-INOX</b>	BI-INOX

---

### \* SF - SPECIAL FINISHES

**MATT BLACK**  
**CORTEN**  
**CRACKLÉ**  
**LEATHER**  
**OSSIDATO**

# La nostra storia

---

L'azienda Frascio nasce nel 1945 come laboratorio artigianale e negli anni ha seguito costantemente un percorso orientato allo sviluppo e alla ricerca nel settore dei complementi e degli accessori per porte e finestre, fino a raggiungere il mercato internazionale che ad oggi costituisce buona parte della clientela. Frascio rappresenta una realtà sempre in grado di rinnovarsi e guardare al futuro, grazie al continuo aggiornamento nel campo del design, della bioarchitettura e delle innovazioni, riservando una particolare attenzione verso le nuove tecniche di lavorazione, l'utilizzo di nuovi materiali ecologici e nuove finiture.

La collaborazione con importanti designers quali Roberto Semprini, Marcello Ziliani, Simone Micheli, Giulio Iacchetti, Adrian e Jeremy Wright, Giacomo Giustizieri e Brian Sironi ha dato vita ai modelli di punta, che arricchiscono una già ampia serie di impugnature create dall'ufficio di Sviluppo Tecnico interno, con la professionalità e la qualità di sempre. La filosofia aziendale di Frascio è quella di offrire servizi e prodotti che possano soddisfare le più diverse esigenze in materia di complementi e accessori per porte e finestre, e di rinnovarsi restando fedeli alla tradizione, mantenendo un perfetto equilibrio tra la forza produttiva di una grande azienda e la sapienza del gesto artigianale nella cura del prodotto. La cura e la ricercatezza delle rifiniture costituiscono l'unicità della nostra produzione e il nostro punto di forza, come anche l'ampiezza di gamma e di materiali usati.

Uno dei principali punti di forza è la completezza della gamma di prodotti: maniglie per porte e finestre, pomoli, maniglioni, kit per porte scorrevoli, nicchie, nottolini, bocchette, set per la sicurezza, set a standard americano, chiavi, serrature, ferma-porte, coprinterruttori e altri accessori coordinati. I principali materiali utilizzati sono l'ottone, la zama, l'acciaio e l'alluminio. Ma una delle particolarità è rappresentata dall'ampia scelta di finiture, tradizionali e speciali.

# Our history

---

Frascio was founded in 1945 as a small workshop. Thanks to a well-planned process of development and research in the field of furniture and accessories for doors and windows, it has evolved into a company with an international market. Frascio represents a reality always able to renew itself and to look to the future, thanks to a continuous updating in the field of design, bioarchitecture and innovations, paying special attention to the new processing techniques and to the use of newest ecological materials and finishes.

The cooperation with Roberto Semprini, Marcello Ziliani, Simone Micheli, Giulio Iacchetti, Adrian e Jeremy Wright, Giacomo Giustizieri and Brian Sironi founded the top models of this year: they will enrich the complete new line that was created from the internal Planning Office and the Technical Development, with the usual professionalism and quality. The Frascio corporate philosophy is now, more than ever before, to offer a new service to meet each kind of requirements, and to renew itself remaining faithful to traditions, maintaining a perfect equilibrium between the productive force of a big company and the wisdom of an artisan gesture in the care of the product. The high attention to details in finishes and the range of materials used, represent the uniqueness and the strength of our production.

One of the main areas of focus is the wide range of products: handles for doors and windows, knobs, pull handles, sliding door handles, thumbturns, escutcheons, security sets, American standard sets, keys, locks, door-stops, switch plates and other accessories for your home. The materials used are brass, zamak, stainless steel and aluminum. One of the specialties is represented by the large range of both traditional and special finishes.



## FRASCIO NEL MONDO

Efficienza significa capacità produttiva ma anche capacità distributiva. Per questo Frascio è presente nel mondo con una distribuzione che assicura una fornitura veloce e puntuale, proponendo una gamma completa di prodotti che comprende: maniglie per porte e finestre, coprinterruttori, pomoli, manettoni ed altri articoli coordinati. La vicinanza al cliente ha reso l'azienda un punto di riferimento nei settori dell'architettura e dell'arredo.

## FRASCIO IN THE WORLD

Efficiency requires manufacturing capacity, but also effective distribution. This is why Frascio covers the world with a distribution network that ensures precise and prompt supply, offering a complete range of products including: handles for doors and windows, switch covers, knobs, hand levers and other coordinated items. Being close to the customer has made the company a global landmark in the world of architecture and interior decoration.



# I Designer

---



## *Giacomo Giustizieri*

Designer toscano che fonde la sua preparazione tecnica (perito meccanico), alla creatività di 2 lauree in disegno industriale. Amante delle arti e di tutte le loro forme di espressione, dalla letteratura alla fotografia, passando

per la musica e la lettura. Attento osservatore, si definisce "operaio della creatività", dal momento che crea i suoi progetti facendo sempre attenzione ai vincoli techno-pratici, chiudendoli in forme semplici e lineari.

Curioso e sperimentatore, con la sua figura eclettica ha maturato una pluriennale esperienza a 360° come creativo, vantando collaborazioni presso grandi aziende quali Philips, Osram e Piaggio. Ha collaborato con Ministero degli Affari Esteri Italiano per lo sviluppo di alcuni eventi internazionali a Roma per la promozione della Cultura e Lingua italiana nel mondo. Nel 2011 vince il premio per il design "Presenta un'idea a Guzzini" con la sua lampada modulare "Periscopio".

Dal 2009 svolge attività di consulenza freelance e insegna disegno e arte in istituti pubblici e privati.



## *BCF*

BCF opera dal 1980. Fin da allora ha mantenuto inalterata come caratteristica peculiare la multidisciplinarietà e la multisettorialità nelle consulenze fornite. Con trent'anni di esperienza alle spalle, BCF rappresenta oggi

uno dei pochi studi di immagine e design che abbia consolidato una profonda cultura di progetto, in grado di offrire una lettura innovativa e contemporaneamente una risposta di sintesi efficace alle problematiche delle imprese. Negli ultimi dieci anni BCF ha ottenuto numerosi riconoscimenti internazionali per il design di prodotto, tra i quali la Menzione d'Onore al Compasso d'Oro 2011.

# Designers

---

## *Giacomo Giustizieri*

Tuscan designer that mixes what he learned in industrial engineering with two industrial design degrees.

He loves all kind of art expressions, from literature to photography, from painting to music. He defines himself as a "creative workman", because when he projects he pays attention to all the technical binds, creating simple and linear shapes. He is curious and an experimenter, and thanks to his eclectic personality he has a lot of experience as a consultant for large companies such as Philips, Osram and Piaggio.

He has collaborated with the Ministero degli Affari Esteri Italiano to promote with international events in Rome the Italian culture and language in the world.

In 2011 he won the award for "Presenta un'idea a Guzzini" with his modular luminaire "Periscopio".

Since 2009 he has been teaching design and art in public and private high schools and he has been a freelancer.

## *BCF*

BCF has been operating since 1980. Since then it has always maintained a unique multidisciplinary and multi-sector approach to its consulting operations. Having built up thirty years of experience, BCF has now become one of the few image and design studios to have consolidated a powerful design culture that is capable to offer innovative insight as well as an effective and concise response to business issues and problems.

In the last ten years BCF has obtained several international product design awards, such as the Compasso d'Oro 2011 Honorable Mention.





### *Marcello Ziliani*

Marcello Ziliani nasce a Brescia nel 1963 sotto il segno dei pesci. Nel 1988 si laurea in architettura al Politecnico di Milano con Achille Castiglioni come relatore (e maestro ineguagliato). Dopo tre anni di esperienza all'estero rientra

in Italia e si dedica prevalentemente al design sviluppando progetti per i settori dell'arredamento, del complemento, dell'illuminazione, del bagno, dell'ufficio, dell'oggettistica e della prima infanzia, occupandosi inoltre di allestimenti, coreografie teatrali, art-direction, coordinazione di design, grafica e comunicazione. Non ama gli assolutismi e le sicurezze incrollabili, gli piace guardare le cose con occhi sempre diversi per entrarvi in sintonia, preferisce parlare piano e soprattutto ascoltare. Crede che qualsiasi progetto sia, in fondo, un desiderio, una speranza di volo e che, nonostante le grandi corse che si fanno agitando inutilmente le braccia, prima o poi dieci metri in planata si riescano anche a fare. Come tutti, chi più chi meno, ha messo da parte la dotazione minima indispensabile di premi e riconoscimenti, ha tenuto conferenze, workshop, fatto parte di giurie, mostre, ecc. Dal 2011 insegna design di prodotto all'università di San Marino/IUAV. Ha firmato progetti per Allibert, BBB, Bertocci, Calligaris, Casprini, Ciacci, Ciatti, Domitalia, Donati, Flex, Flou, Flos, Fontana Arte, Frascio, Geuther, Inglesina, Infiniti, ISA, Krios, Krover, Lanzini, Magis, Modo e Modo, Norda, Olympia, Opinion Ciatti, Pali, Parri, Progetti, Rapsel, Roche Bobois, Sintesi, Techimpex, Vanini, Views International, Visentin, Zago.

CD  
GL

### *CDGL*

Proseguendo una storica collaborazione familiare nata negli anni '60 tra l'architetto Caccia Dominioni e l'azienda guidata in quel momento da Bruno Lualdi, i figli Antonio e Ambrogio, con l'intento di onorare una tradizione entrata a far

parte della cultura del design italiano, lavorano di nuovo insieme per ripensare oggetti di uso quotidiano.

Enrico Gollo da oltre 20 anni si occupa di Industrial design, prima come socio di Piano Design Workshop, in seguito fonda lo studio Ergo Design collaborando negli anni con diverse aziende. I suoi progetti hanno vinto vari premi quali Compasso d'Oro, If Design Award, premio Innovazione ADI Design Index 2016.

### *Marcello Ziliani*

Marcello Ziliani was born in Brescia in 1963 under the sign of Pisces. In 1988 he graduated in architecture at the Politecnico di Milano with Achille Castiglioni as a supervisor (and unmatched teacher). After three years abroad, he returned to Italy and devoted himself mainly to the development of projects for the design of furniture, complement, lighting, bathroom, office, objects and early childhood, working in addition for exhibitions, theatrical choreography, art direction, design coordination, graphics and communication. He doesn't like the absolutism and the indestructible certainties, he loves to look at things with always different eyes to be in tune with them, he prefers to speak softly and, above all to listen. He believes that any project is, after all, a desire, a hope of flight. He believes that, despite the great run you can do waving your arms uselessly, sooner or later you can have your ten meters of gliding. Like all the designers, more or less, he put aside the minimum necessary equipment of prizes and awards, he has given lectures, workshops, he served on juries and so on. Since 2011 he's been a professor of product design at the University of San Marino / IUAV. He signed projects for Allibert, BBB, Bertocci, Calligaris, Casprini, Ciacci, Ciatti, Domitalia, Donati, Flex, Flou, Flos, Fontana Arte, Frascio, Geuther, Inglesina, Infiniti, ISA, Krios, Krover, Lanzini, Magis, Modo e Modo, Norda, Olympia, Opinion Ciatti, Pali, Parri, Progetti, Rapsel, Roche Bobois, Sintesi, Techimpex, Vanini, Views International, Visentin, Zago.

### *CDGL*

Following a historic family collaboration born in the 60s between the architect Caccia Dominioni and the company led at that time by Bruno Lualdi, the sons Anthony and Ambrose, with the intent to honor a tradition become part of the culture of the Italian design, work again together in rethinking everyday objects.

Enrico Gollo has been dealing for over 20 years with Industrial Design, previously as a design partner of Plan Workshop, later founding the Ergo Design studio that has collaborated over the years with various companies.

His designs have won several awards such as Golden Compass, If Design Award, Innovation Award ADI Design Index 2016.



### *Adrian e Jeremy Wright*

Design Wright è lo studio dei fratelli Adrian e Jeremy Wright con base a Londra. Specializzati nel design per arredamento di interni e accessori, grazie al loro background di studi in ingegneria, riescono a catturare tutti gli aspetti, visivi e tecnici,

dei prodotti che vanno a realizzare. Sono un piccolo laboratorio di idee, con un forte carattere, che consente loro di spaziare in varie discipline senza alcun limite.

### *Adrian e Jeremy Wright*

Design Wright is the London-based design practice of the English brothers Adrian and Jeremy Wright. Specialized in product and furniture design, thanks to their background in engineering, their work is often characterized by their appreciation of both the visual and technical aspects of a project. They're a small but professional practice working across a wide range of design disciplines, and they welcome projects of all size and can advise on any creative matter.



### *Brian Sironi*

Brian Sironi nasce a Seregno (MI) nel 1977. Si laurea in Design al Politecnico di Milano e prosegue la sua formazione collaborando con architetti e designer. Il suo percorso formativo si colloca nel cuore della Brianza, a contatto con varie

professionalità del sistema-design: falegnami, fabbri, intagliatori, tappezzieri. Una formazione metà artigianale e metà accademica, con un radicamento sul territorio che è parte integrante del suo progetto di designer italiano e cosmopolita. Infatti prosegue il suo percorso negli Stati Uniti e al suo ritorno, nel gennaio del 2008, fonda il suo Studio Brian Sironi, specializzato in product design, interior design e architettura. Nel suo lavoro si concentra sulla connessione tra oggetto e utilizzatore, forma e funzione, puntando alla forma nella sua purezza. Nel 2009 vince il premio "Design dello stupore" al concorso "Young & Design", nel 2010 ottiene molti altri riconoscimenti, come i premi internazionali "If Gold Award", "Good Design Award" e "Red Dot Design Award". A soli 33 anni, nell'edizione del 2011, vince il "Compasso d'Oro" per la lampada "Elica" prodotta da "Martinelli luce".

### *Brian Sironi*

Brian Sironi was born in Seregno (Italy) in 1977. He graduated at the Politecnico in Milan with a degree in Industrial Design and then began collaborating with architects, designers and professional artisans in the design industry such as carpenters, blacksmiths, wood carvers and upholsterers. Trained in the heart of Brianza, his background is both practical and academic with a strong connection to the territory, an integral element featured in his cosmopolitan Italian designs. In 2007, Brian continued his training in the United States and after his return to Italy, he established his own firm, Studio Brian Sironi, specialized in product design, interior design and architecture. In his work, he focuses on the connection between object and user, shape and function, while aiming for form in his purity. In 2009 he received the special prize "Il Design dello Stupore" in the Contest "Young & Design", in 2010 he received many other awards, such as the prestigious "IF Gold Award", "Good Design Award" and "Red Dot Design Award". At the age of 33 he won the "Compasso d'Oro Edition 2011" award for the lamp "Elica" produced by "Martinelli Luce".



### *Controdesign*

Fondato nel 1989 da Marcella Spinelli e Marcello Oggioni, lo Studio Controdesign nel corso degli anni ha collaborato con numerose aziende prevalentemente nel settore dell'arredamento, progettando prodotti di design.

### *Controdesign*

Founded in 1989 by Marcella Spinelli and Marcello Oggioni, Studio Controdesign has worked over the years with many companies, mainly in the furniture industry, planning design products.



### *Simone Micheli*

Simone Micheli fonda l'omonimo Studio d'Architettura nel 1990 e nel 2003 la società di progettazione "Simone Micheli Architectural Hero" con sede a Firenze e Milano. La sua attività professionale si articola in plurime direzioni: dall'architettura

all'architettura d'interni, dal design al visual design passando per la comunicazione; le sue creazioni, sostenibili e sempre attente all'ambiente, sono connotate da forte identità e unicità. Le numerose realizzazioni per pubbliche amministrazioni e importanti committenze private connesse al mondo residenziale e della collettività, ne fanno uno dei principali attori nella dimensione progettuale europea. Molte sono le pubblicazioni su riviste italiane e internazionali, le interviste televisive dedicate alla sua opera e le monografie, tra cui "Simone Micheli From the Future to the Past", edita nel 2012, che rappresenta una selezione di 20 anni del suo fare progettuale.



### *Giulio Iacchetti*

Giulio Iacchetti, nato nel 1966, si occupa di industrial design dal 1992. All'attività di progettista alterna l'insegnamento presso numerose università e scuole di design, in Italia e all'estero. Caratteri distintivi del suo fare sono la ricerca e la

definizione di nuove tipologie oggettuali, come il Moscardino, posata multiuso biodegradabile per cui, nel 2001, si aggiudica, con Matteo Ragni, il Compasso d'Oro ed entra a far parte della collezione permanente del design al MoMA di New York. Con l'ideazione e il coordinamento del progetto collettivo Eureka Coop, realizzato per Coop Italia, ha portato il design nella grande distribuzione organizzata e caratterizzato la nuova generazione del design italiano. Nel 2009 questo progetto gli è valso il Premio dei Premi per l'innovazione conferitogli dal Presidente della Repubblica Italiana. All'attività di progettista si aggiunge la direzione artistica per importanti marchi come IB rubinetterie, ceramica Globo e Il Coccio design edition. Per Corraini Edizioni ha curato il libro *Italianità*, una raccolta di interventi relativi agli oggetti, ai simboli, agli odori, ai sapori e ai suoni che contribuiscono a formare la coscienza del popolo italiano. Nel maggio 2009 la Triennale di Milano ha ospitato una sua mostra personale intitolata "Giulio Iacchetti. Oggetti disobbedienti".

### *Simone Micheli*

In 1990 he founded the architectural studio that bears his name, and in 2003 the architecture and design company "Simone Micheli Architectural Hero", based in Florence and Milan. His professional activity moves in different directions: from architecture to interior design, and from industrial design to visual design going through mass-media and social media. His creations, ecofriendly and oriented to nature, are defined by strong identity and uniqueness. There are many publications on Italian and international magazines, television interviews dedicated to his works and monographs, such as "Simone Micheli from the Future to the Past", published in 2012, which represents a selection of his 20 years of design activity.

### *Giulio Iacchetti*

Giulio Iacchetti, born in 1966, has worked in the field of industrial design since 1992. He alternates this activity with teaching in many universities and schools of design in Italy and abroad. The distinctive characteristics of his work are research and definition of new object typologies, like the Moscardino, the multiuse biodegradable utensil for which in 2001, together with Matteo Ragni, he won the Compasso d'Oro, with the object becoming part of the permanent design collection of MoMA New York. The concept and coordination of the group project Eureka Coop, for Coop Italia, brought design into the major retailing circuit and focused on the new generation of Italian design. In 2009 this project won the Premio dei Premi for the innovation bestowed by the President of the Italian Republic. He works as art director for important brands like IB rubinetterie, Ceramica Globo and Il Coccio design edition. For Corraini Edizioni he has edited the book "Italianità", a collection of contributions on objects, symbols, odors, flavors and sounds that contribute to form the consciousness of the Italian people. In May 2009 the Milan Triennale held a solo show of his work entitled "Giulio Iacchetti. Disobedient Objects".





### *Roberto Semprini*

Nato a Rimini nel 1959, Roberto Semprini studia architettura a Firenze. Nel 1987 aderisce al movimento Bolidista, che esprime il design in chiave simbolica e come sintesi di un concetto di velocità elettronica. Trasferitosi a Milano

inizia a collaborare come giornalista freelance per alcune riviste di design come *Modo*, *L'Atelier* (Parigi) e *ARDI* (Barcellona). Nel 1989 esce il divano "Tatlin" di Edra, che risulta tra i prodotti vincitori del prestigioso premio TOP TEN a Dusseldorf. Nel 1994 con il tavolino "Manta" per Fiam è tra i vincitori del premio Young & Design.

I suoi prodotti fanno parte della collezione permanente del Montreal Museum of Decorative Arts in Canada e del New Museum of Design di Londra. Nel 2000 si trasferisce a Rimini dove inaugura lo spazio "RM 12 art & design", Galleria d'arte e Studio di Design e Architettura di Interni. Dal 2006 lo studio realizza scenografie di grande impatto, inerenti la ricerca di nuovi spazi domestici e pubblici, all'interno della parte culturale di eventi fieristici come il Sia di Rimini, il Fuori Salone di Milano, Abitare il Tempo a Verona e Sun di Rimini. Nel 2007 è stato invitato dal Seoul Living design Fair (Korea) ad esporre "La casa Italo/coreana". Ha collaborato con numerose aziende di design come Fiam, Moroso, Alivar, Rede Guzzini, Edra, Ciacci, R.S.V.P., Arredaesse, Sicis, Slide, Trivellini, Contempo, Ciacci Kreaty, Larms, Spaus, Ad Hoc, M.B., Gruppo Trend, Frighetto, Dilmos, Adrenalina, Morfeus, Mastella Design, Pedrali, Morellato, Scab, Valdichienti ecc. Ha tenuto conferenze e seminari in diverse facoltà di design come: facoltà di Architettura di Firenze, Politecnico di Milano, Scuola Superiore di Progettazione dell'Università degli Studi di Bologna, I.E.D. di Milano, I.A.V. di Orleans e Scuola Elisava di Barcellona, ecc. Attualmente è docente di ruolo e Coordinatore del Corso di Progettazione Artistica per l'Impresa all'Accademia di Belle Arti di Brera.

### *Roberto Semprini*

Born in Rimini in 1959, Roberto Semprini studied architecture in Florence. In 1987 he joined the Bolidismo trend that expresses the design in a symbolic and synthesis of a concept of electronic speed. He moved to Milan and started working as a freelance journalist for several design magazines like *Mode*, *L'Atelier* (Paris) and *ARDI* (Barcelona). In 1989, he realized the sofa "Tatlin" Edra, which is one of the winners of the prestigious TOP TEN in Dusseldorf. In 1994, with the table "Manta" for Fiam is among the winners of the Young & Design. His products are part of the permanent collection of the Montreal Museum of Decorative Arts in Canada and the New Museum of Design in London. In 2000 he moved to Rimini, where he launched the space "RM 12 Art & Design" Gallery and Studio of Design and Interior Architecture. Since 2006 the studio has realized high-impact scenography, regarding the search for new domestic and public spaces, within cultural events such as exhibitions SIA in Rimini, Fuori Salone del Mobile in Milan, Abitare il Tempo in Verona and Sun in Rimini. In 2007 he was invited by the Seoul Living Design Fair (Korea) to exhibit "The Italian / Korean house." He has collaborated with numerous design firms like Fiam, Moroso, Alivar, Rede Guzzini, Edra, Ciacci, RSVP, Arredaesse, Sicis, Slide, Trivellini, Contempo, Ciacci Kreaty, Larms, Spaus, Ad Hoc, MB, Trend Group, Frighetto, Dilmos, Adrenaline, Morfeus, Mastella Design, Pedrali, Morellato, Scab, Valdichienti etc. He has given lectures and seminars in various faculties of design such as the Faculty of Architecture in Florence, the Polytechnic in Milan, the School of Engineering, the University of Bologna, the I.E.D. in Milan, the I.A.V. in Orleans and the School Elisava Barcelona, etc. He is currently role Professor and Coordinator of the Artistic Project Class for the Business Academy of Fine Arts in Brera.







# La nostra ricerca

---

Lo Studio di Progettazione e Sviluppo Tecnico è un vero e proprio laboratorio di ricerca. I nostri tecnici creano prodotti nuovi e rielaborano modelli classici per aggiornarli, all'occorrenza, secondo le richieste del mercato. Questo reparto ci consente inoltre di progettare articoli su misura per aziende partner, come produttori di porte e finestre, e di sviluppare giorno dopo giorno la ricerca dei materiali. Un nuovo elemento è la collaborazione con creativi, grafici, architetti e designers esterni, per la creazione di articoli particolari e la realizzazione di progetti innovativi. Grazie a queste partnership continua il nostro percorso nel mondo del design, perché siamo fortemente convinti che rinnovarsi ed evolvere siano le carte vincenti per stare sempre al passo con i tempi ed essere davvero competitivi. Tutti i nostri clienti oggi ci riconoscono un merito: aver realizzato un perfetto equilibrio tra la forza produttiva di una grande azienda e la sapienza del gesto artigianale nella cura del prodotto. Due mondi che sanno dialogare e interagire: il pensiero che progetta, che pianifica e la mano esperta che produce, che guida la tecnologia e trasmette ad ogni singolo pezzo i valori del marchio Frascio: il design, la cura delle finiture, la qualità del prodotto. Una grande organizzazione che genera una produzione di maniglie ed accessori in linea con le esigenze e le aspettative del cliente per volumi di prodotto e tempi di consegna.

## LA TECNOLOGIA E LA SICUREZZA

Da sempre attenti ai singoli elementi della produzione, abbiamo sviluppato al nostro interno un sistema finalizzato a garantire elevati standard qualitativi. Personale altamente qualificato che si dedica alla ricerca continua di nuove soluzioni, tecnici di grande esperienza che sviluppano i prodotti, selezionano i materiali ed effettuano test e continui controlli e collaudi sui pezzi durante la lavorazione.

# Our research

---

Our technical Project and Development department is a research laboratory where technicians create new products and revise classic models according to market requirements. This office also creates O.E.M. products for commercial partners, including door and window manufacturers, and creates new designs in cooperation with graphic designers and architects, to support innovative projects. Thanks to these partnerships, we continue our journey round the world of design, because we believe that renewal and progress are essential to our continuous competitiveness.

All our customers now recognize one of our points of excellence: the perfect balance between the manufacturing power of a great company and the skilled eye and hand of our craftsmen. Two worlds that interact and intertwine: the mind that plans and designs, the human hand that guides technology and impresses upon each individual item the philosophy of Frascio - beautiful design, perfect finish, absolute quality. A great organization which creates handles and accessories to meet the demands and expectations of customers also in terms of volumes and delivery times.

## TECHNOLOGY AND SAFETY

Always paying attention to each aspect of the production, we have created an internal system to ensure the highest levels of quality. Expert research staff works constantly to discover new solutions, highly experienced technicians develop products, select materials and constantly carry out tests, monitoring products all the way through the production cycle.

## UNI ISO 9001:2015

E' garanzia di qualità e sicurezza per i clienti la certificazione UNI ISO 9001/2015, con la quale l'azienda testimonia il suo impegno e volontà di offrire e mantenere standard produttivi di ottimo livello.

## UNI ISO 9001:2015

It is quality and safety guarantee for customers the UNI ISO 9001/2015 certification, with which the company demonstrates its commitment and willingness to offer and maintain high-quality production standards.



## FINITURE

Dopo oltre 70 anni, Frascio non perde la sua attenzione per le nuove tendenze e le nuove tecnologie, proponendo sempre nuovi prodotti e nuove finiture al passo con le mode e le tradizioni, ricreando materiali e suggestioni tutte da scoprire.

L'irregolare trama del cuoio invecchiato, l'architettonico Corten e le finiture PVD antigraffio su base cromata e perla che regalano colori unici, senza dimenticare il modaiolo antracite.

## FINISHES

After 70 years, Frascio doesn't lose its attention for new trends and new technologies and proposes new products and new finishes in line with fashions and traditions, recreating materials and suggestions all to be discovered.

The irregular texture of old leather, the architectural Corten, the PVD anti-scratch finishes on a chrome or pearl basis, that give unique colours, without forgetting the trendy antracite.



## PVD

La costante ricerca nel campo delle tecnologie ci ha consentito di mettere a punto speciali lavorazioni. Una di queste è il trattamento PVD, che ci permette di realizzare le finiture INOX BRASS®, INOXBRONZE® e INOX CHROME®, che rendono le superfici inossidabili e i prodotti inattaccabili dagli agenti esterni. Inoltre, test e regolari controlli durante il ciclo di lavorazione assicurano gli elevati standard qualitativi, che contraddistinguono da sempre la nostra produzione.

La certificazione di sistema è garantita da DNV secondo le norme UNI EN ISO 9001:2008.

## PVD

Through constant research in technology, we have been able to improve our processes. By using advanced PVD technology we can produce INOX BRASS®, INOXBRONZE® and INOX CHROME® finishes, which render the surface impregnable against damage from normal use such as oxidation, wear and abrasion. Moreover, tests and regular checks during the production cycle ensure the highest levels of quality, which have always distinguished our production.

The quality management system is certified by DNV accordingly to UNI EN ISO 9001:2008.



## ANTRACITE BY FRASCIO

Frascio ha sviluppato una nuova finitura, Antracite, realizzata su base satinata tramite la tecnologia PVD (Physical Vapor Deposition o deposizione fisica da vapore) che protegge la superficie del prodotto dai graffi e dall'usura del tempo e viene garantita per 15 anni. La finitura è proposta su un numero selezionato di prodotti a catalogo e associata al nuovo sistema di rosetta bassa Thin, sia tonda sia quadrata, alta solo 5 mm. Tra i prodotti: la nuova Join (design Giacomo Giustizieri) e prodotti di riferimento come Ibis, Pavone, Fenice (rispettivamente progettati da Giulio Iacchetti, Controdesign e Marcello Ziliani).

## ANTRACITE BY FRASCIO

Frascio has developed a new finish - Antracite - realized on a satin base through PVD (Physical Vapor Deposition) technology, which protects the surface of the product from scratches, wear and tear, with 15 years warranty. The finish is available for a limited number of products, and associated to the new low-profile rose system THIN introduced by Frascio, round or squared, 5 mm thickness. Among the products: Join (design Giacomo Giustizieri) and reference products like Ibis, Pavone, Fenice (respectively designed by Giulio Iacchetti, Controdesign and Marcello Ziliani).

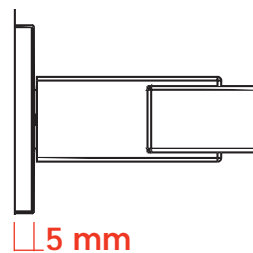
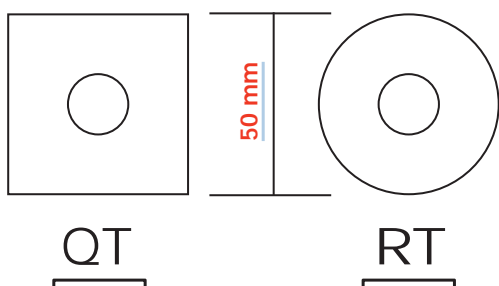

## THIN

Thin è il nuovo sistema di rosetta bassa progettato da Frascio che permette di avere bassi spessori senza ulteriori lavorazioni sulla porta.

- montaggio veloce e pulito
- NO lavorazioni aggiuntive, NO polveri residue
- spessore 5 mm

## THIN

Thin is the new low-profile rose system introduced by Frascio, low profile thickness and ready to install without additional modifications on the door.

- Fast and clean to install
- NO additional drilling steps required and therefore NO mess
- Thickness 5 mm





**TENDENZA  
TREND**



# Blade



ZAMA/ZAMAK



*Brian Sironi design*



**1500/50 Q**

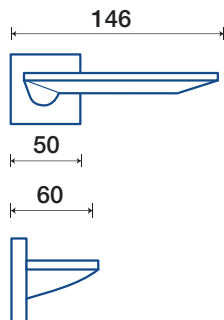

**1500/32 Q DK**

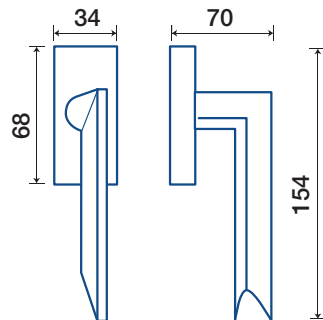

CROMO LUCIDO  
POLISHED CHROME



CROMO SATINATO  
SATIN CHROME



BIANCO  
WHITE



NERO OPACO  
MATT BLACK



OSSIDATO  
OSSIDATO



CORTEN  
CORTEN



CRACKLÉ  
CRACKLÉ



LEATHER  
LEATHER



LONDON NIGHT LUCIDO  
LONDON NIGHT POLISHED



LONDON NIGHT SATINATO  
LONDON NIGHT SATIN



RED COPPER LUCIDO  
RED COPPER POLISHED



RED COPPER SATINATO  
RED COPPER SATIN



GREY STONE  
GREY STONE



BRONZO TREND  
BRONZE TREND



NICKEL SATINATO  
SATIN NICKEL



# Eidos



ZAMA/ZAMAK



*Brian Sironi design*



630/50 Q

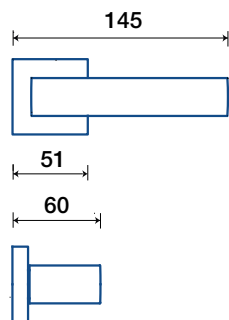

630/32 Q DK

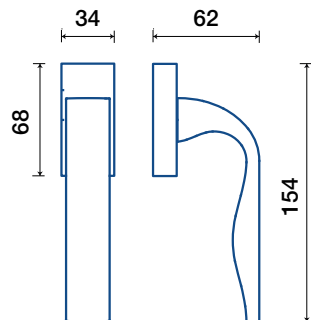

CROMO LUCIDO  
POLISHED CHROME



CROMO SATINATO  
SATIN CHROME



BIANCO  
WHITE



NERO OPACO  
MATT BLACK



OSSIDATO  
OSSIDATO



CORTEN  
CORTEN



CRACKLÉ  
CRACKLÉ



LEATHER  
LEATHER



LONDON NIGHT LUCIDO  
LONDON NIGHT POLISHED



LONDON NIGHT SATINATO  
LONDON NIGHT SATIN



RED COPPER LUCIDO  
RED COPPER POLISHED



RED COPPER SATINATO  
RED COPPER SATIN



GREY STONE  
GREY STONE



BRONZO TREND  
BRONZE TREND



NICKEL SATINATO  
SATIN NICKEL



# Jam



ZAMA/ZAMAK



*Frascio design*



**639/50 Q**

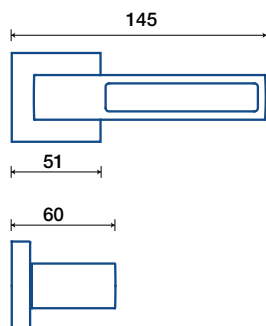

**639/32 Q DK**

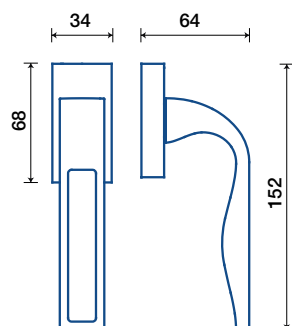

**CROMO LUCIDO**  
POLISHED CHROME



**CROMO SATINATO**  
SATIN CHROME



**NICKEL SATINATO**  
SATIN NICKEL



**BRONZO TREND**  
BRONZE TREND



**RED COPPER LUCIDO**  
RED COPPER POLISHED



**RED COPPER SATINATO**  
RED COPPER SATIN



**LONDON NIGHT LUCIDO**  
LONDON NIGHT POLISHED



**LONDON NIGHT SATINATO**  
LONDON NIGHT SATIN



**GREY STONE**  
GREY STONE





# Tuke



ZAMA/ZAMAK



*Brian Sironi design*



620/50 Q

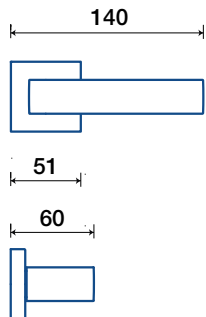

620/32 Q DK

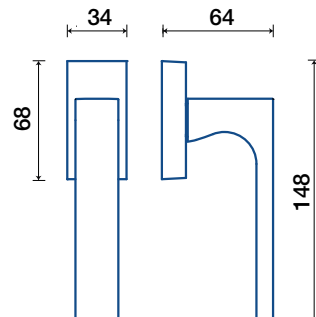

CROMO LUCIDO  
POLISHED CHROME



CROMO SATINATO  
SATIN CHROME



BIANCO  
WHITE



NERO OPACO  
MATT BLACK



OSSIDATO  
OSSIDATO



CORTEN  
CORTEN



CRACKLÉ  
CRACKLÉ



LEATHER  
LEATHER



LONDON NIGHT LUCIDO  
LONDON NIGHT POLISHED



LONDON NIGHT SATINATO  
LONDON NIGHT SATIN



RED COPPER LUCIDO  
RED COPPER POLISHED



RED COPPER SATINATO  
RED COPPER SATIN



GREY STONE  
GREY STONE



BRONZO TREND  
BRONZE TREND



NICKEL SATINATO  
SATIN NICKEL



# Tuke Glass

ZAMA/ZAMAK



*Brian Sironi design*



**625/50 Q**

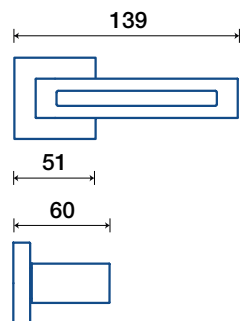

**625/32 Q DK**

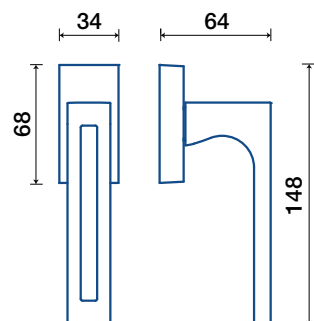

CROMO LUCIDO  
POLISHED CHROME



CROMO SATINATO  
SATIN CHROME



CROMO LUCIDO  
POLISHED CHROME



CROMO SATINATO  
SATIN CHROME



CROMO LUCIDO  
POLISHED CHROME



CROMO SATINATO  
SATIN CHROME



# Sharp

ZAMA/ZAMAK



*Brian Sironi design*



**1580/50 QR**

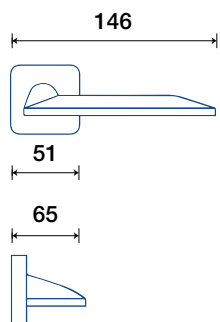

**1580/32 DK**

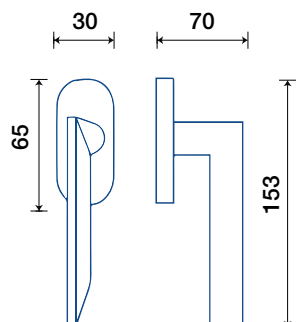

CROMO LUCIDO  
POLISHED CHROME



CROMO SATINATO  
SATIN CHROME





# Sweep

OTTONE/BRASS



*Roberto Semprini design*



**720/50 Q**

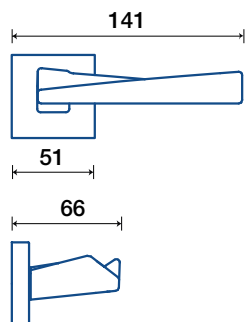

**720/32 Q DK**

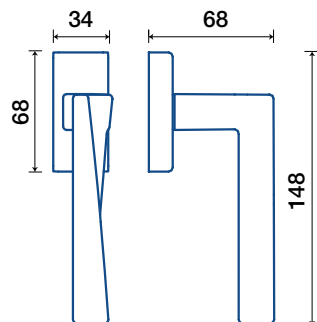

CROMO LUCIDO  
POLISHED CHROME



CROMO SATINATO  
SATIN CHROME

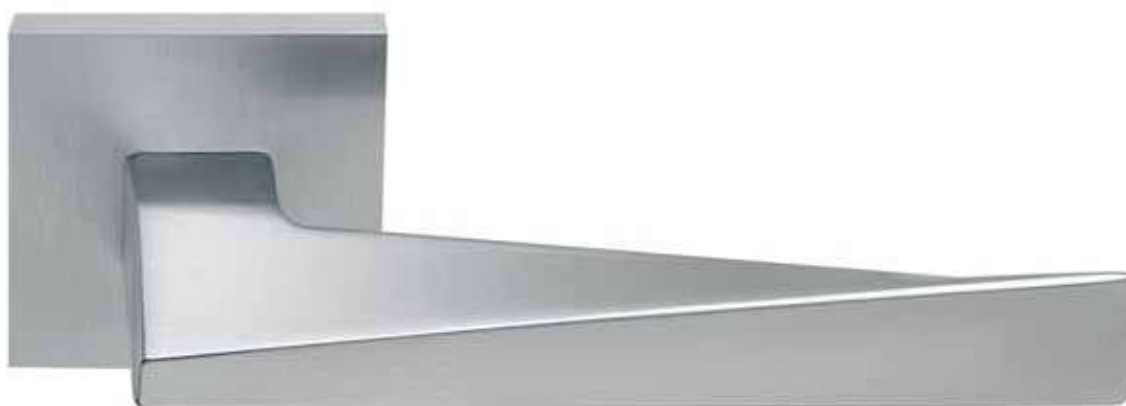

# Inner

ZAMA/ZAMAK



*Brian Sironi design*



660/50 QR

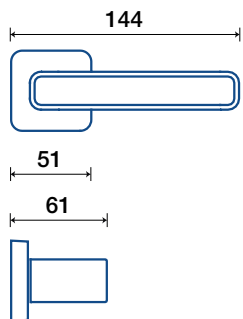

660/32 DK

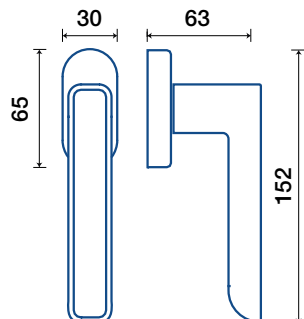

INNER METAL



CROMO LUCIDO  
POLISHED CHROME



CROMO SATINATO  
SATIN CHROME



INNER GLASS



CROMO LUCIDO  
POLISHED CHROME



CROMO SATINATO  
SATIN CHROME



INNER WOOD  
WENGÉ



CROMO LUCIDO  
POLISHED CHROME



CROMO SATINATO  
SATIN CHROME



INNER WOOD  
ROVERE/OAK



CROMO LUCIDO  
POLISHED CHROME



CROMO SATINATO  
SATIN CHROME



# Leaf

ZAMA/ZAMAK



*Brian Sironi design*



**1520/50 I**

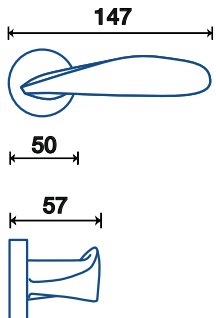

**1520/32 DK**

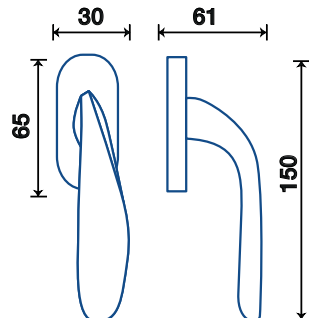

CROMO LUCIDO  
POLISHED CHROME



CROMO SATINATO  
SATIN CHROME



ANTICO OPACO  
MATT ANTIQUE BRASS



# Ice Q

ZAMA/ZAMAK



*Frascio design*



1540/50 QR

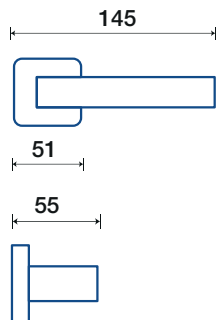

1540/31 Q DK

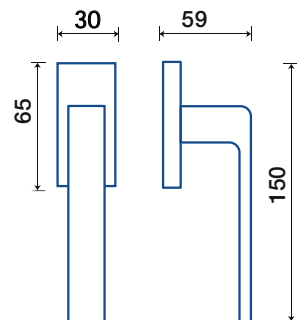



CROMO LUCIDO  
POLISHED CHROME



CROMO SATINATO  
SATIN CHROME



# Ice Plus

CROMO SATINATO / CROMO LUCIDO  
SATIN CHROME / POLISHED CHROME

ZAMA/ZAMAK



*Frascio design*

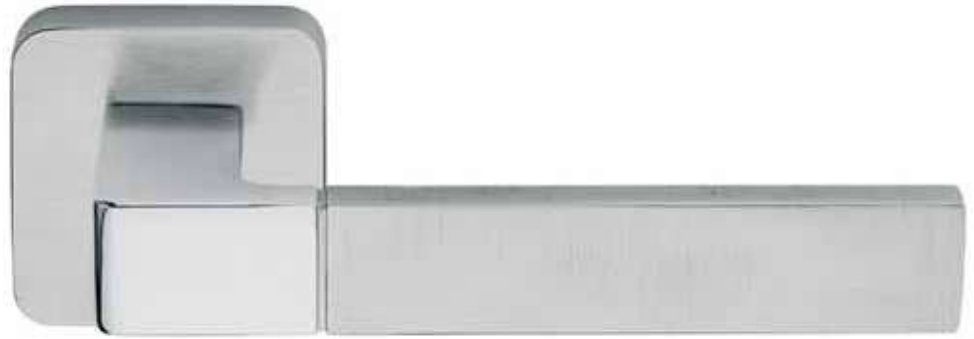

1550/50 QR

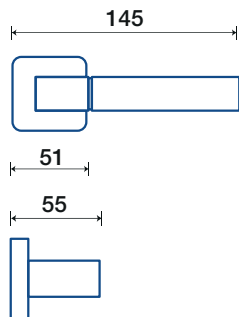

1550/31 Q DK

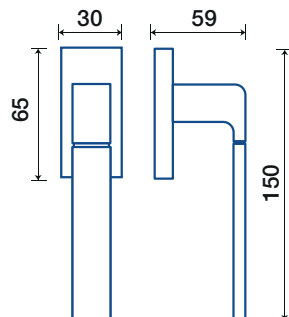

# Slim

CROMO LUCIDO  
POLISHED CHROME

ZAMA/ZAMAK



*Simone Micheli design*

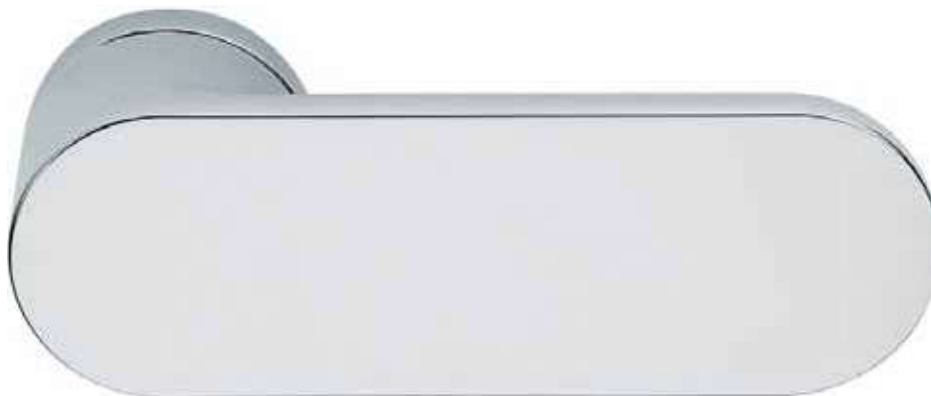

1560/50 I

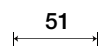
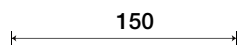

**Frascio**

# Flow

OTTONE/BRASS



*Adrian e Jeremy Wright design*



700/50 QR

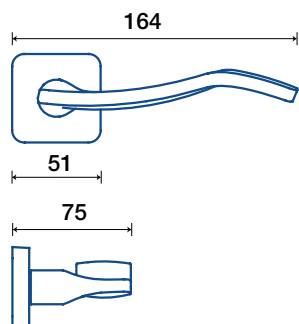

700/32 DK

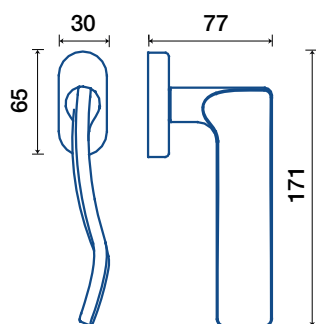

CROMO LUCIDO  
POLISHED CHROME



CROMO SATINATO  
SATIN CHROME



# Flow Round

OTTONE/BRASS



*Adrian e Jeremy Wright design*



700/50 I

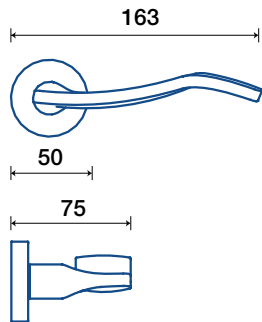

700/32 DK

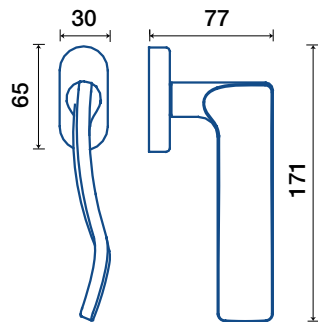

CROMO LUCIDO  
POLISHED CHROME



CROMO SATINATO  
SATIN CHROME



# Aria

OTTONE/BRASS



*Brian Sironi design*



710/50 QR

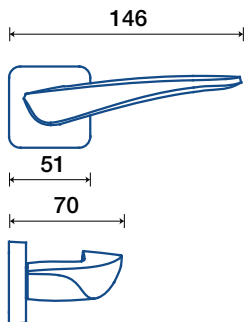

710/32 DK

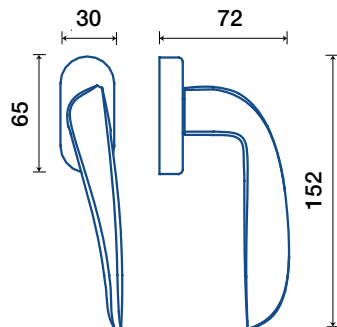



CROMO LUCIDO  
POLISHED CHROME



CROMO SATINATO  
SATIN CHROME



# Aria Round

OTTONE/BRASS



*Brian Sironi design*

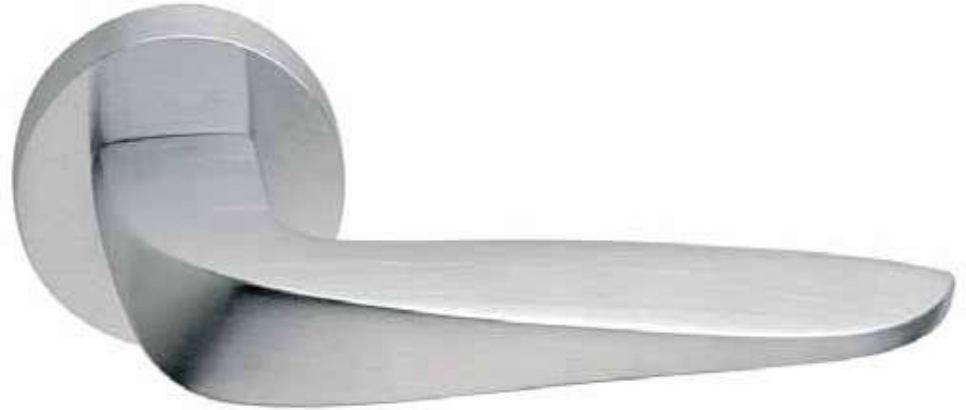

710/50 I

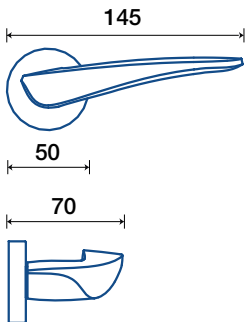

710/32 DK

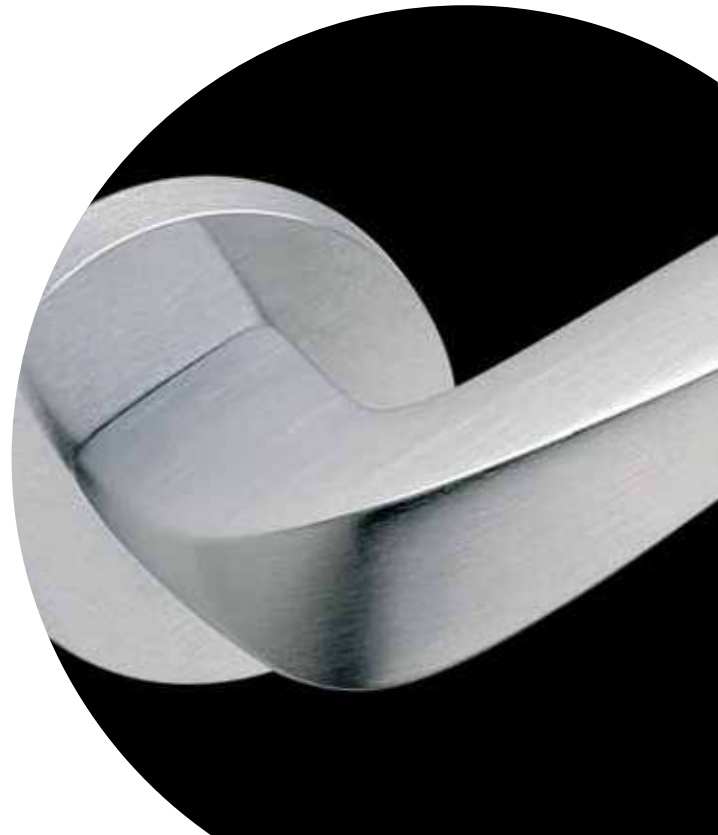
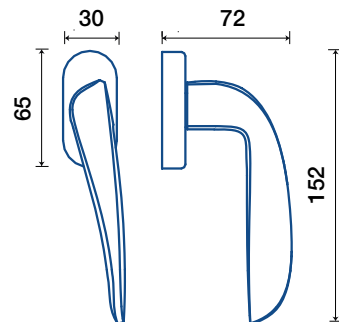

OTTONE LUCIDO VERNICIATO  
POLISHED BRASS



CROMO SATINATO  
SATIN CHROME

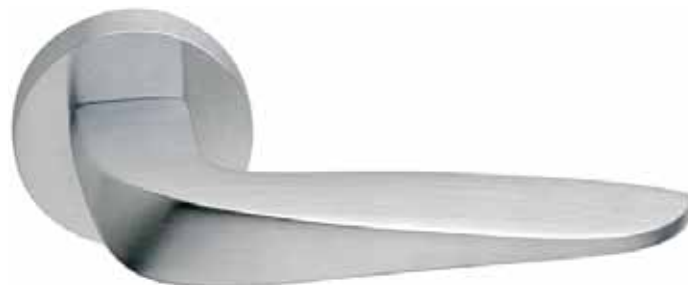

ANTICO OPACO  
MATT ANTIQUE BRASS



# Kuma

OTTONE/BRASS



*Brian Sironi design*



**640/50 I**

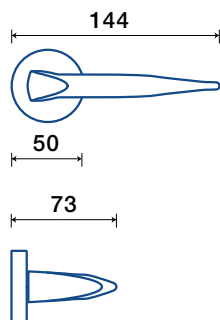

**640/32 DK**

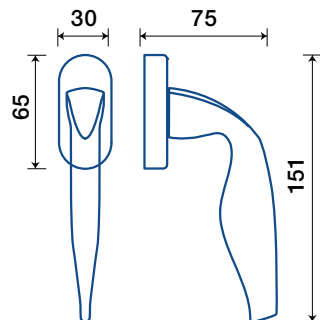

CROMO LUCIDO  
POLISHED CHROME



CROMO SATINATO  
SATIN CHROME



OTTONE LUCIDO VERNICIATO  
POLISHED BRASS



ANTICO OPACO  
MATT ANTIQUE BRASS



# Pinax

ZAMA/ZAMAK



*Brian Sironi design*



610/50 Q

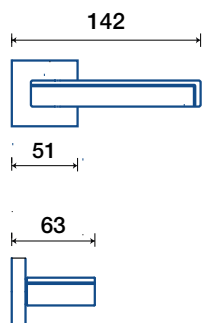

610/32 Q DK

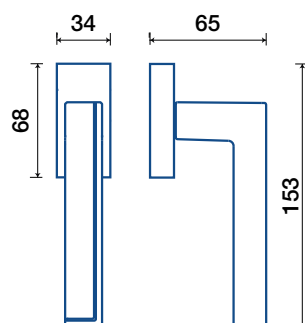

CROMO SATINATO E LUCIDO  
SATIN AND POLISHED CHROME



CROMO SATINATO  
SATIN CHROME

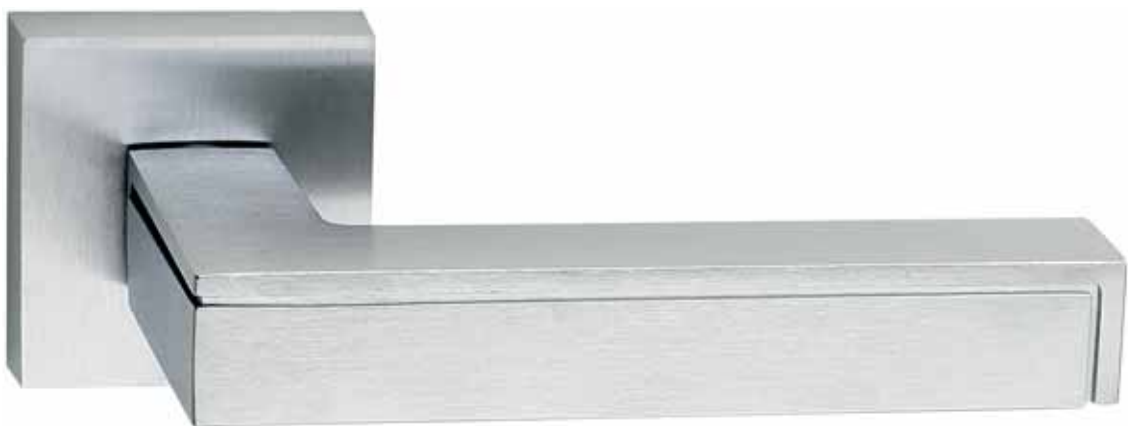

# Kalè

ZAMA/ZAMAK



*Frascio design*



650/50 Q

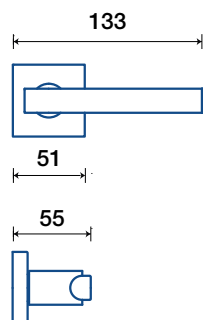

650/32 Q DK

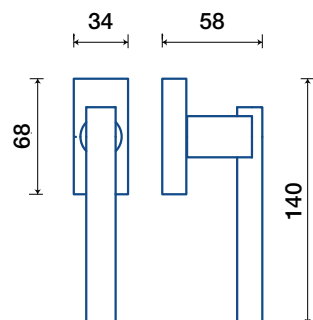



CROMO LUCIDO  
POLISHED CHROME



CROMO SATINATO  
SATIN CHROME



CROMO SATINATO / CROMO LUCIDO  
SATIN CHROME / POLISHED CHROME



# Modulo Q

OTTONE/BRASS



*Frascio design*



745/50 Q

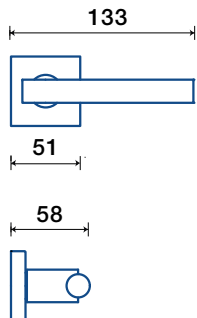

745/32 Q DK

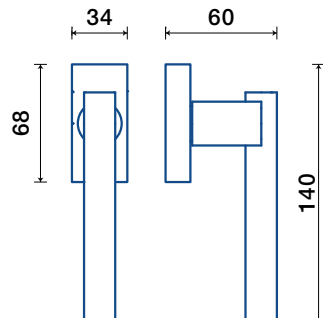

CROMO LUCIDO  
POLISHED CHROME

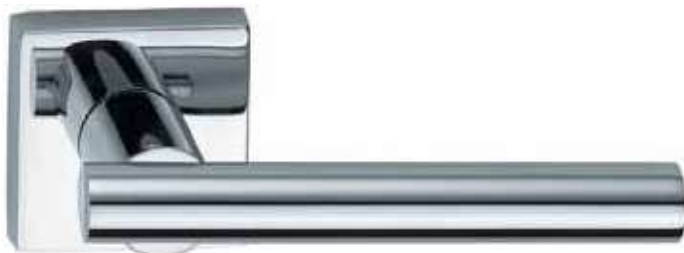

CROMO SATINATO  
SATIN CHROME



CROMO SATINATO / CROMO LUCIDO  
SATIN CHROME / POLISHED CHROME



# Jour

ZAMA/ZAMAK



*Frascio design*

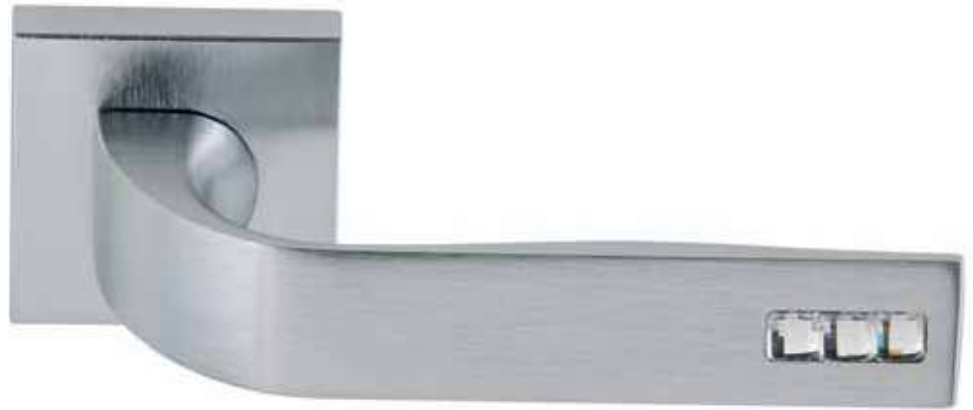

633/50 Q

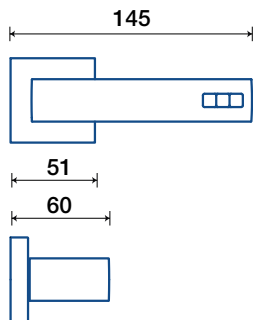

633/32 Q DK

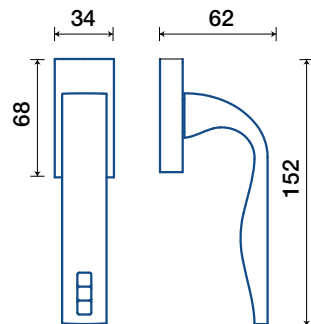

CROMO LUCIDO  
POLISHED CHROME



CROMO SATINATO  
SATIN CHROME



BRONZO TREND  
BRONZE TREND



# Chic

ZAMA/ZAMAK



*Frascio design*



631/50 Q

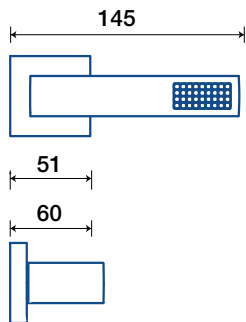

631/32 Q DK

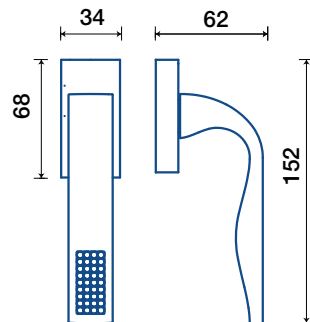



CROMO LUCIDO  
POLISHED CHROME



CROMO SATINATO  
SATIN CHROME



BRONZO TREND  
BRONZE TREND



# Queen

ZAMA/ZAMAK



*Frascio design*

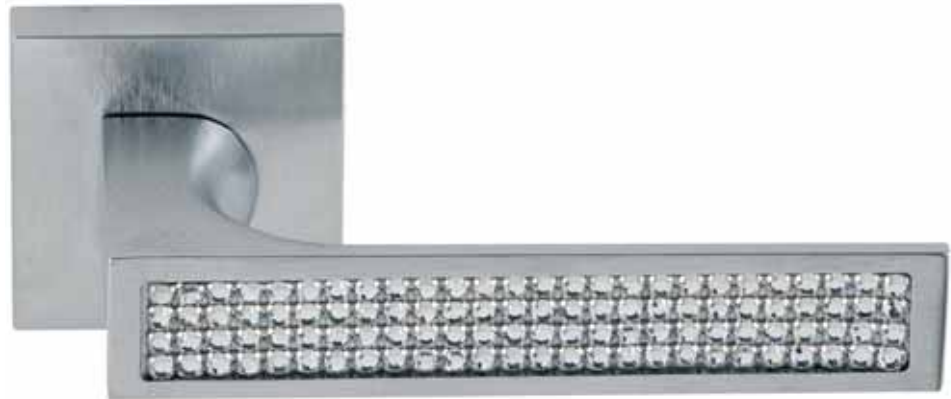

621/50 Q

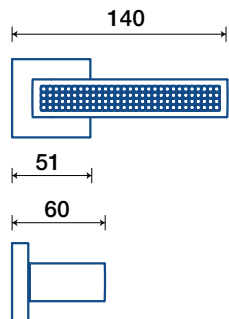

621/32 Q DK

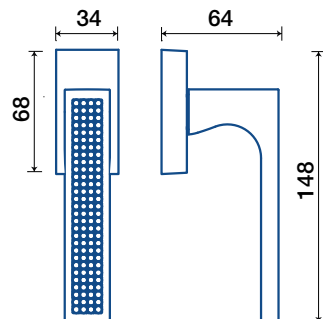

CROMO LUCIDO  
POLISHED CHROME



CROMO SATINATO  
SATIN CHROME



BRONZO TREND  
BRONZE TREND



# Nuit

ZAMA/ZAMAK



*Frascio design*



632/50 Q

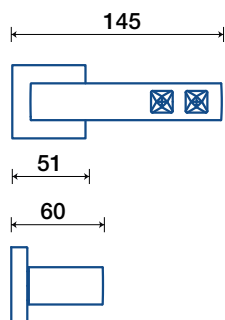

632/32 Q DK

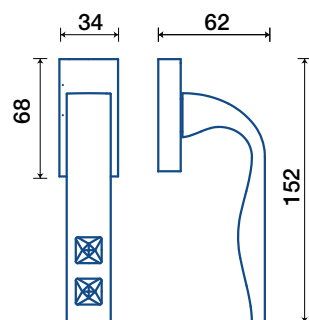

CROMO LUCIDO  
POLISHED CHROME



CROMO SATINATO  
SATIN CHROME



BRONZO TREND  
BRONZE TREND



# King

ZAMA/ZAMAK



*Frascio design*



623/50 Q

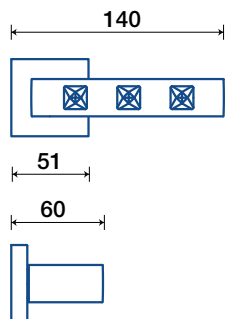

623/32 Q DK

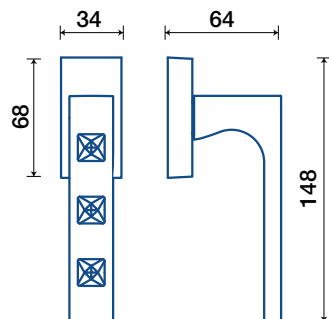

CROMO LUCIDO  
POLISHED CHROME



CROMO SATINATO  
SATIN CHROME



BRONZO TREND  
BRONZE TREND





18/1

# Pomolini per mobili / Furniture knobs

CROMO LUCIDO  
POLISHED CHROME



CROMO SATINATO  
SATIN CHROME



INOX BRASS  
INOX BRASS



BRONZO TREND  
BRONZE TREND



20/4

CROMO LUCIDO  
POLISHED CHROME



CROMO SATINATO  
SATIN CHROME



INOX BRASS  
INOX BRASS



BRONZO TREND  
BRONZE TREND



18/9

CROMO LUCIDO  
POLISHED CHROME



CROMO SATINATO  
SATIN CHROME



INOX BRASS  
INOX BRASS



BRONZO TREND  
BRONZE TREND



24/1

CROMO LUCIDO  
POLISHED CHROME



CROMO SATINATO  
SATIN CHROME



INOX BRASS  
INOX BRASS



BRONZO TREND  
BRONZE TREND







ACCIAIO  
STAINLESS STEEL

# Straight

ACCIAIO/STAINLESS STEEL



*Adrian e Jeremy Wright design*



**280/51 Q**

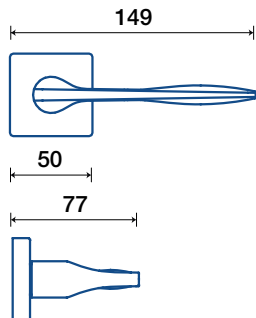

**280/31 Q DK**

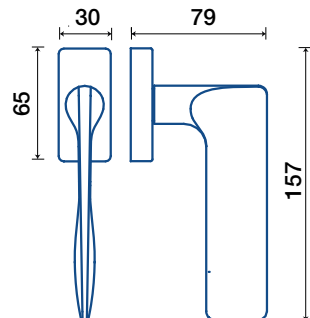

ACCIAIO LUCIDO  
POLISHED STAINLESS STEEL



ACCIAIO SATINATO  
SATIN STAINLESS STEEL



# Kube

ACCIAIO SATINATO  
SATIN STAINLESS STEEL

ACCIAIO/STAINLESS STEEL



*Frascio design*



290/51 Q

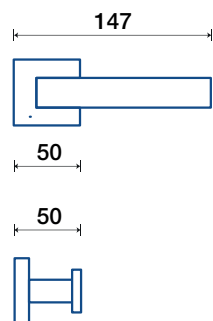

290/31 Q DK

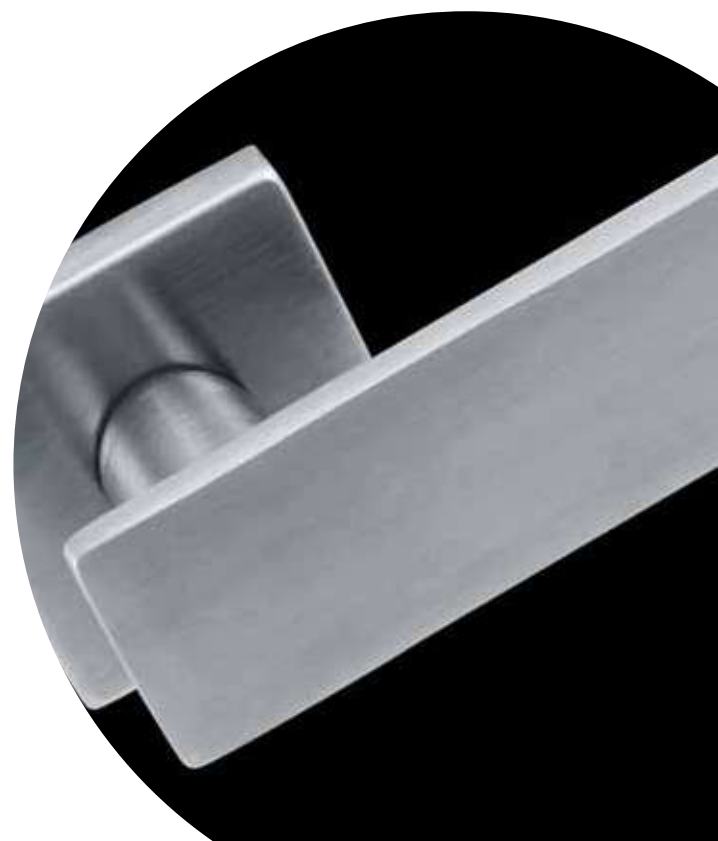
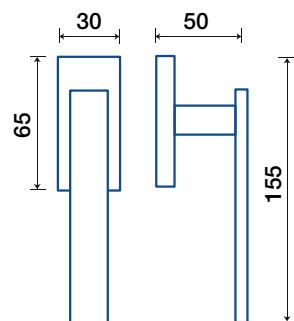

# Alfa



*Frascio design*

ACCIAIO SATINATO  
SATIN STAINLESS STEEL

ACCIAIO/STAINLESS STEEL



220/51 Q

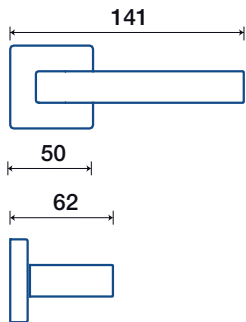

220/31 Q DK

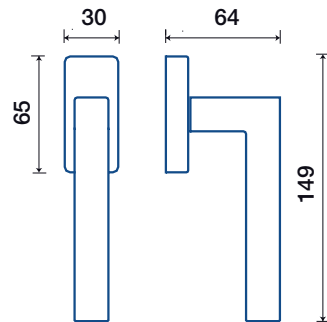



# Beta

ACCIAIO SATINATO  
SATIN STAINLESS STEEL

ACCIAIO/STAINLESS STEEL



*Frascio design*



**230/51 Q**

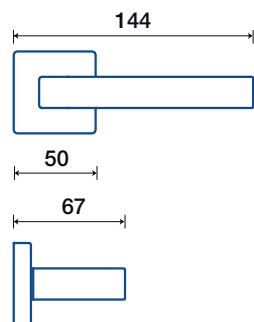

**230/31 Q DK**

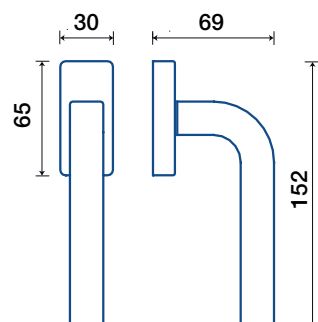

# Christina

BICOLORE  
BICOLOUR

ACCIAIO/STAINLESS STEEL



*Frascio design*



**5850/K 52**

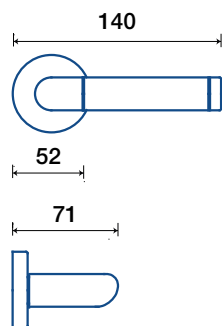

**5850/32 DK**

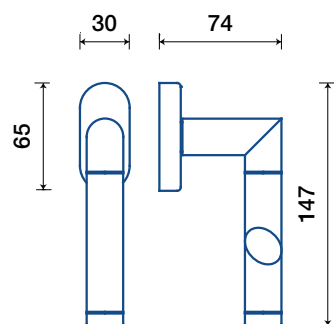

# Loredana

BICOLORE  
BICOLOUR

ACCIAIO/STAINLESS STEEL



*Frascio design*



5700/K 52

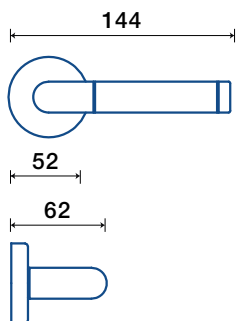

5700/32 DK

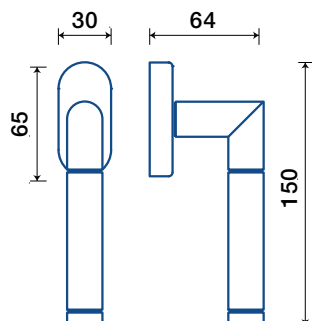

# Loredana Square

ACCIAIO/STAINLESS STEEL



*Frascio design*



BICOLORE

BICOLOUR



5700 51 Q

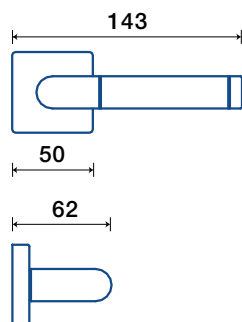

5700/31 Q DK

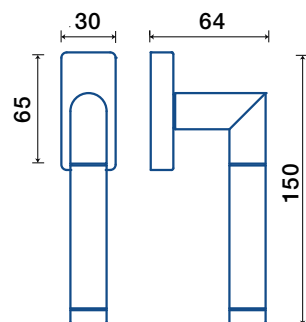

# Adina

BICOLORE  
BICOLOUR

ACCIAIO/STAINLESS STEEL



*Frascio design*



5750/K 52

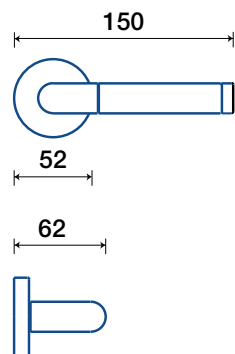

5750/32 DK

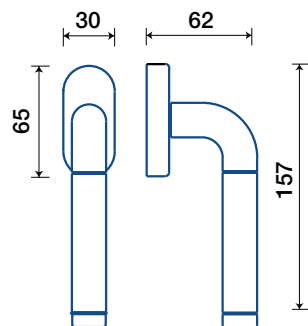

# Alessia

ACCIAIO SATINATO  
SATIN STAINLESS STEEL

ACCIAIO/STAINLESS STEEL



*Frascio design*



5000/K 52

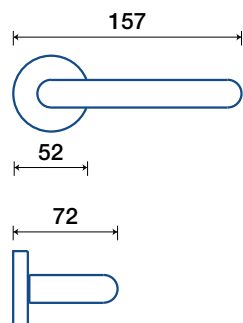

5000/32 DK

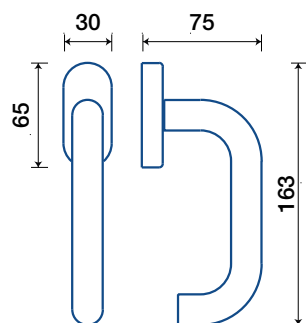

# Loft



*Frascio design*

ACCIAIO SATINATO  
SATIN STAINLESS STEEL

ACCIAIO/STAINLESS STEEL



**5200/K 52**

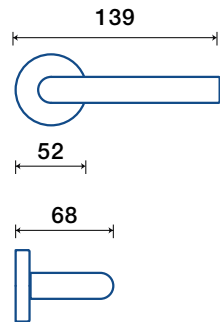

**5200/32 DK**

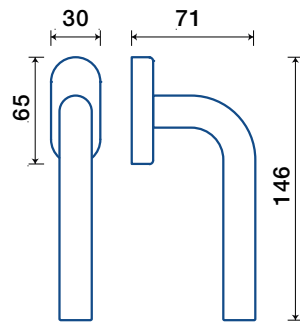

# Lucia

ACCIAIO SATINATO  
SATIN STAINLESS STEEL

ACCIAIO/STAINLESS STEEL



*Frascio design*



5100/K 52

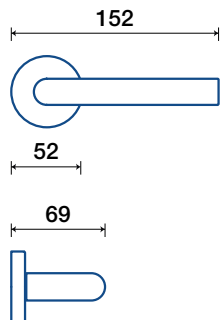

5100/32 DK

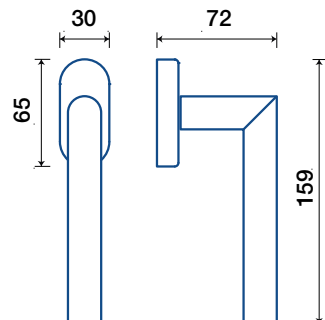



# Lucia Square

ACCIAIO/STAINLESS STEEL



*Frascio design*



ACCIAIO SATINATO  
SATIN STAINLESS STEEL



5100/51 Q

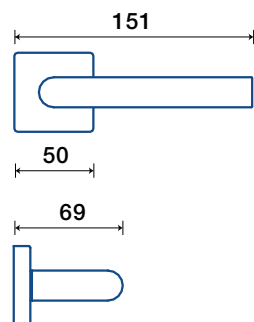

5100/31 Q DK

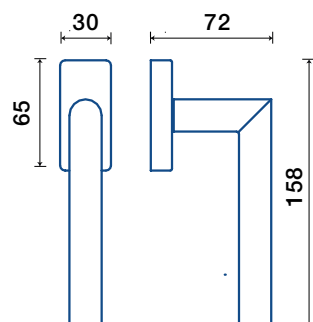





THIN  
THIN

# Rake QT

ALLUMINIO/ALUMINIUM



*Giacomo Giustizieri design*



**920/50 QT**

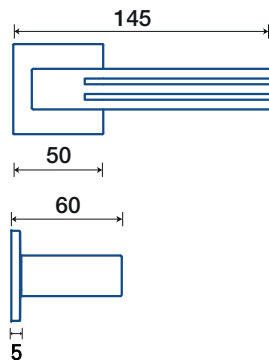

**920/32 Q DK**

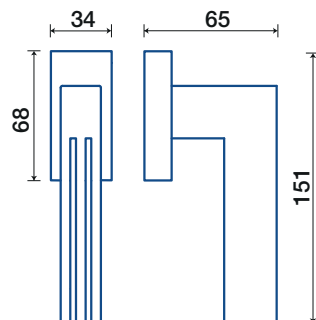

BIANCO  
WHITE



NERO OPACO  
MATT BLACK



# Opera2 RT

OTTONE/BRASS



*Giulio Iacchetti design*



307/50 RT

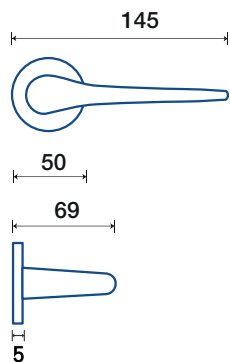

307/32 DK

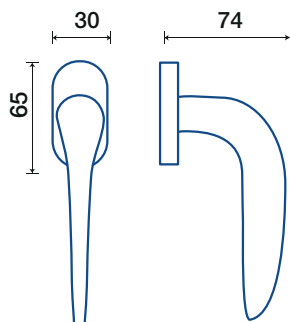

CROMO LUCIDO  
POLISHED CHROME



CROMO SATINATO  
SATIN CHROME



# Blade QT



ZAMA/ZAMAK



*Brian Sironi design*



**1500/50 QT**

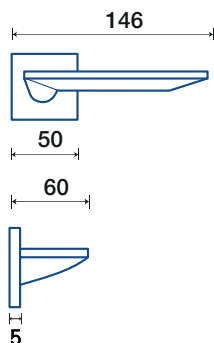

**1500/32 Q DK**

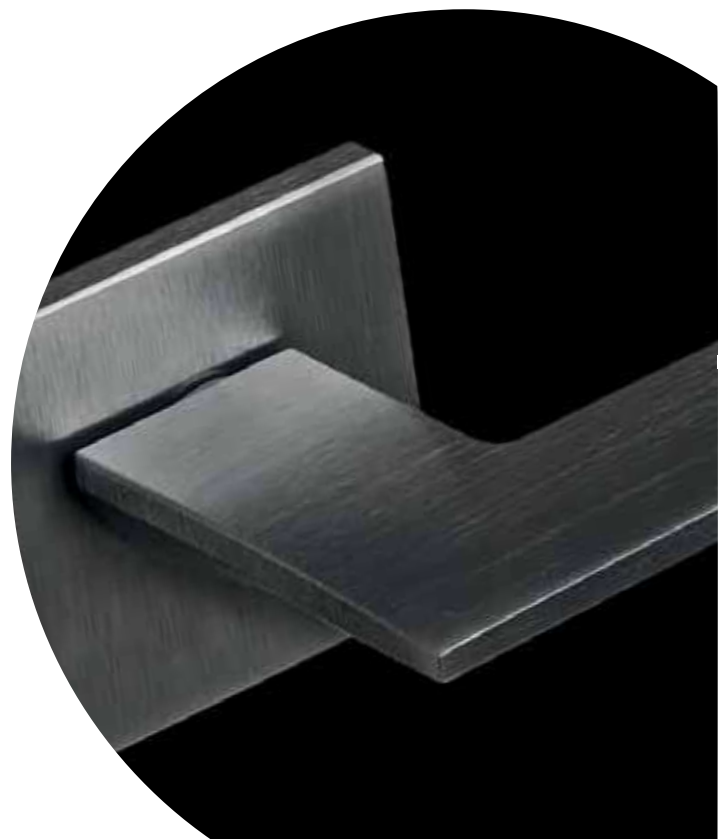
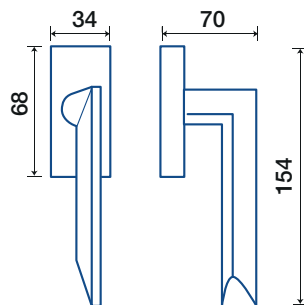



CROMO LUCIDO  
POLISHED CHROME



CROMO SATINATO  
SATIN CHROME



NICKEL SATINATO  
SATIN NICKEL



ANTRACITE  
ANTRACITE



# Eidos QT



ZAMA/ZAMAK



*Brian Sironi design*



**630/50 QT**

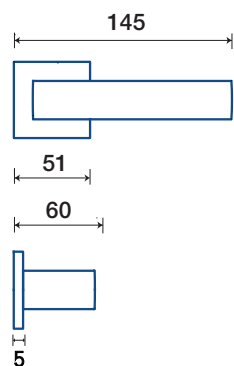

**630/32 Q DK**

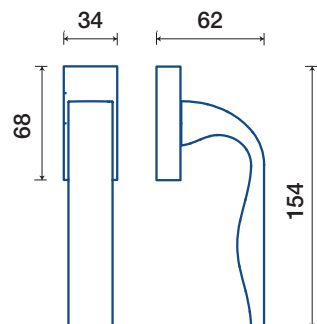

CROMO LUCIDO  
POLISHED CHROME



CROMO SATINATO  
SATIN CHROME



NICKEL SATINATO  
SATIN NICKEL



ANTRACITE  
ANTRACITE



# Tuke QT



ZAMA/ZAMAK



*Brian Sironi design*



**620/50 QT**

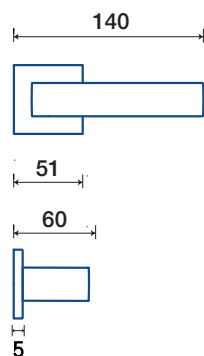

**620/32 Q DK**

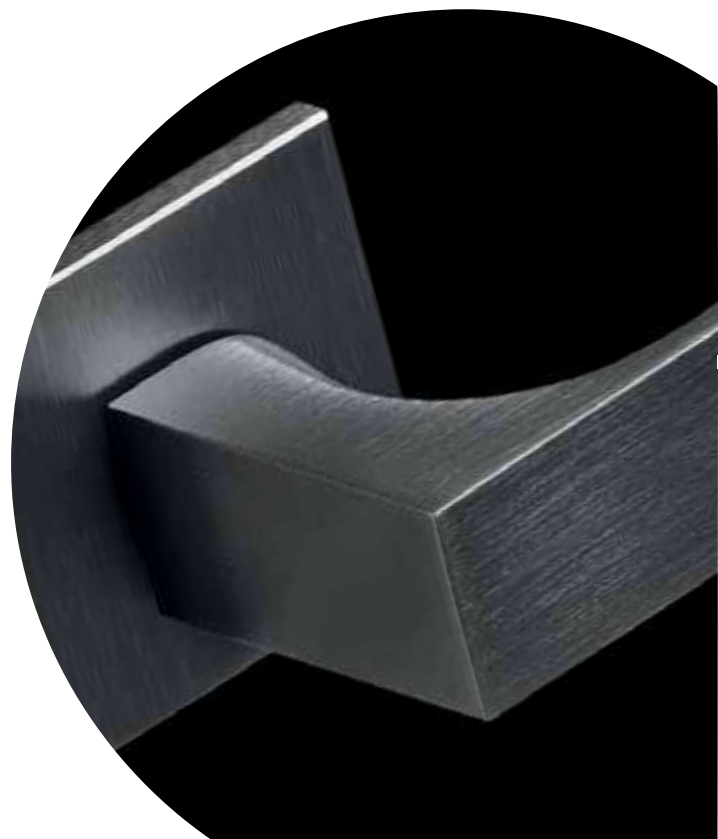
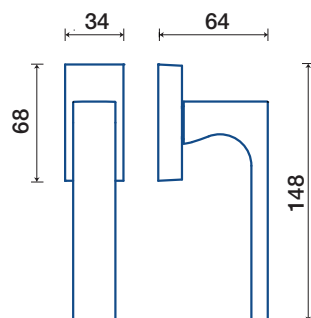

CROMO LUCIDO  
POLISHED CHROME



CROMO SATINATO  
SATIN CHROME

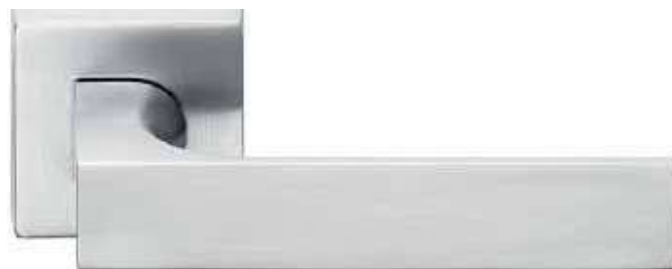

NICKEL SATINATO  
SATIN NICKEL



ANTRACITE  
ANTRACITE

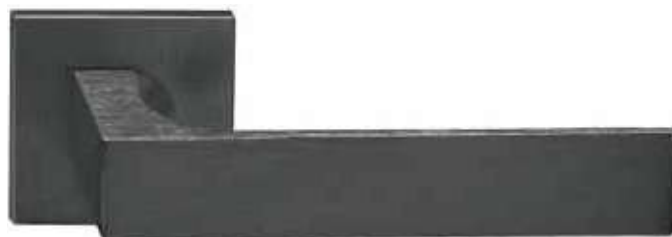

# Jam QT



ZAMA/ZAMAK



*Frascio design*



**639/50 QT**

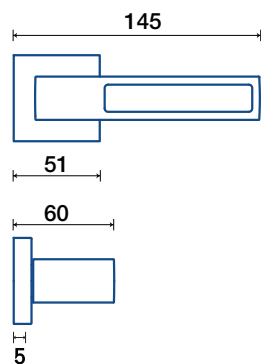

**639/32 Q DK**

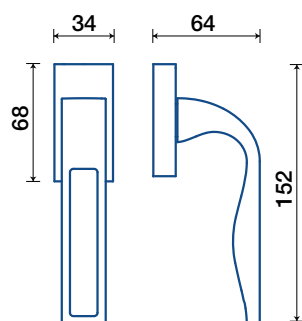

CROMO LUCIDO  
POLISHED CHROME



CROMO SATINATO  
SATIN CHROME



NICKEL SATINATO  
SATIN NICKEL



ANTRACITE  
ANTRACITE



# Join QT



*Giacomo Giustizieri design*



**925/50 QT**

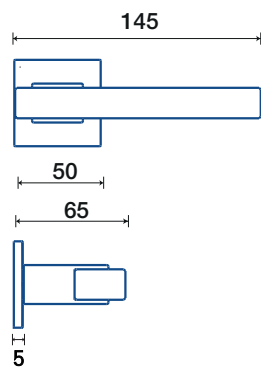

**925/32 Q DK**

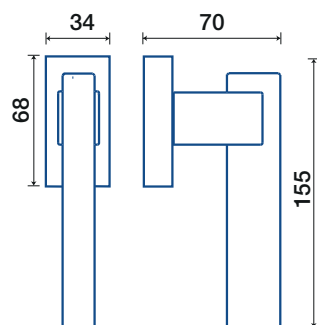



# METAL

ACCIAIO SATINATO/CROMO LUCIDO  
SATIN STAINLESS STEEL/POLISHED CHROME



ACCIAIO LUCIDO/CROMO SATINATO  
POLISHED STAINLESS STEEL/SATIN CHROME

ANTRACITE  
ANTRACITE



# OTTONE / ACRILICO - BRASS / ACRYLIC

BLANC/CROMO LUCIDO  
BLANC/POLISHED CHROME



BLANC/CROMO SATINATO  
BLANC/SATIN CHROME

DARK/CROMO LUCIDO  
DARK/POLISHED CHROME



DARK/CROMO SATINATO  
DARK/SATIN CHROME

PEPPER/CROMO LUCIDO  
PEPPER/POLISHED CHROME



PEPPER/CROMO SATINATO  
PEPPER/SATIN CHROME

GHOST/CROMO LUCIDO  
GHOST/POLISHED CHROME



GHOST/CROMO SATINATO  
GHOST/SATIN CHROME

# Ibis RT



OTTONE/BRASS



*Giulio Iacchetti design*



**500/50 RT**

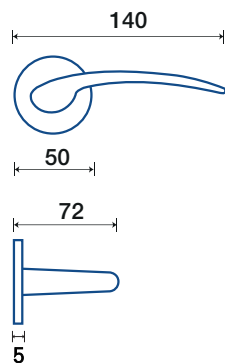

**500/32 DK**

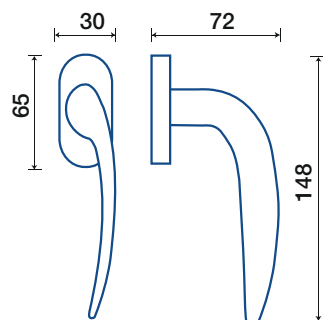

CROMO LUCIDO  
POLISHED CHROME



CROMO SATINATO  
SATIN CHROME



RED COPPER LUCIDO  
RED COPPER POLISHED



RED COPPER SATINATO  
RED COPPER SATIN



LONDON NIGHT LUCIDO  
LONDON NIGHT POLISHED



LONDON NIGHT SATINATO  
LONDON NIGHT SATIN



ANTRACITE  
ANTRACITE



# Pavone RT



OTTONE/BRASS



*Controdesign design*



**505/50 RT**

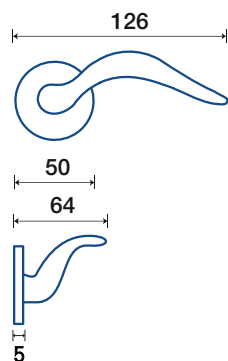

**505/32 DK**

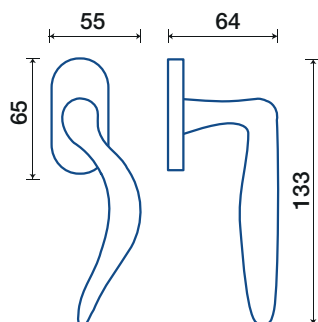

CROMO LUCIDO  
POLISHED CHROME



CROMO SATINATO  
SATIN CHROME



RED COPPER LUCIDO  
RED COPPER POLISHED



RED COPPER SATINATO  
RED COPPER SATIN



LONDON NIGHT LUCIDO  
LONDON NIGHT POLISHED



LONDON NIGHT SATINATO  
LONDON NIGHT SATIN



ANTRACITE  
ANTRACITE



# Fenice RT



OTTONE/BRASS



*Marcello Ziliani design*



**503/50 RT**

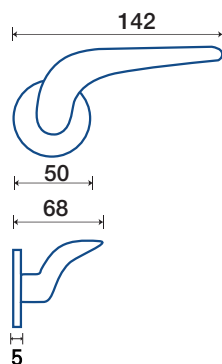

**503/32 DK**

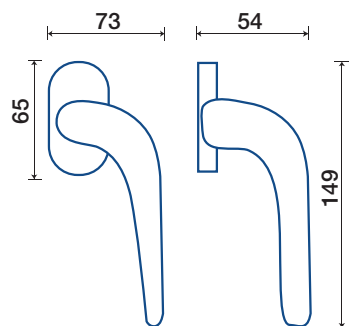

CROMO LUCIDO  
POLISHED CHROME



CROMO SATINATO  
SATIN CHROME



RED COPPER LUCIDO  
RED COPPER POLISHED



RED COPPER SATINATO  
RED COPPER SATIN



LONDON NIGHT LUCIDO  
LONDON NIGHT POLISHED



LONDON NIGHT SATINATO  
LONDON NIGHT SATIN



ANTRACITE  
ANTRACITE





# Filoo RT



ZAMA/ZAMAK

## CD GL

*CDGL design*



**1210/50 RT**

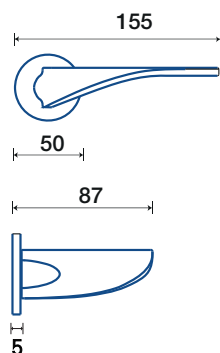

**1210/32 DK**

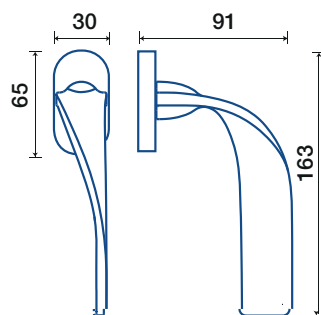



CROMO LUCIDO  
POLISHED CHROME



CROMO SATINATO  
SATIN CHROME



RED COPPER LUCIDO  
RED COPPER POLISHED



RED COPPER SATINATO  
RED COPPER SATIN



LONDON NIGHT LUCIDO  
LONDON NIGHT POLISHED



LONDON NIGHT SATINATO  
LONDON NIGHT SATIN



NICKEL SATINATO  
SATIN NICKEL



ANTRACITE  
ANTRACITE



# Bump RT



ZAMA/ZAMAK



*Brian Sironi design*



**1200/50 RT**

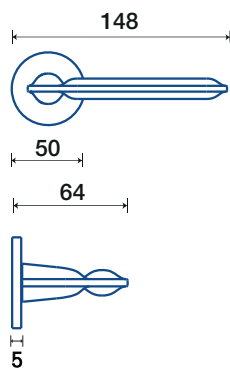

**1200/32 DK**

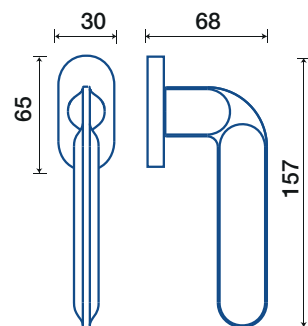

CROMO LUCIDO  
POLISHED CHROME



CROMO SATINATO  
SATIN CHROME



BRONZO TREND  
BRONZE TREND



ANTRACITE  
ANTRACITE



# Duck RT



ZAMA/ZAMAK



*Giulio Iacchetti design*



**1220/50 RT**

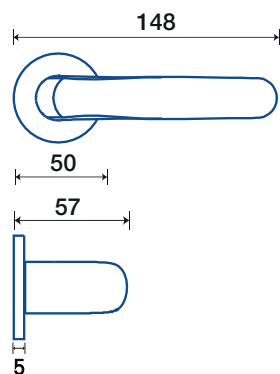

**1220/32 DK**

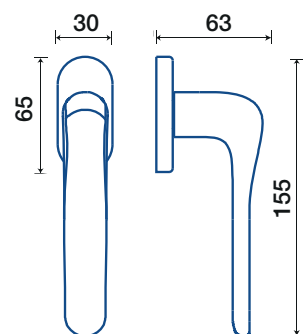

CROMO LUCIDO  
POLISHED CHROME



CROMO SATINATO  
SATIN CHROME



BRONZO TREND  
BRONZE TREND



ANTRACITE  
ANTRACITE



# Kuma RT



ANTRACITE  
ANTRACITE

OTTONE/BRASS



*Brian Sironi design*



640/50 RT

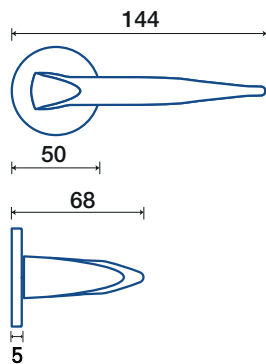

640/32 DK

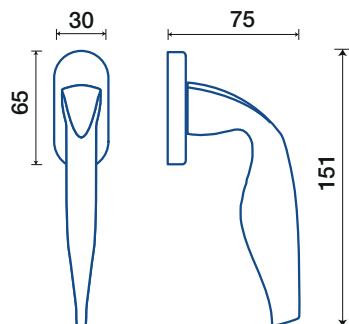

# Kalè QT



ANTRACITE  
ANTRACITE

ZAMA/ZAMAK



*Frascio design*



650/50 QT

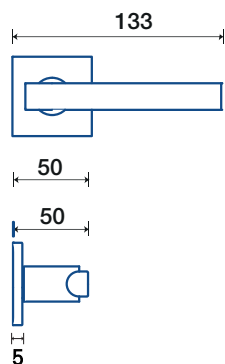

650/32 Q DK

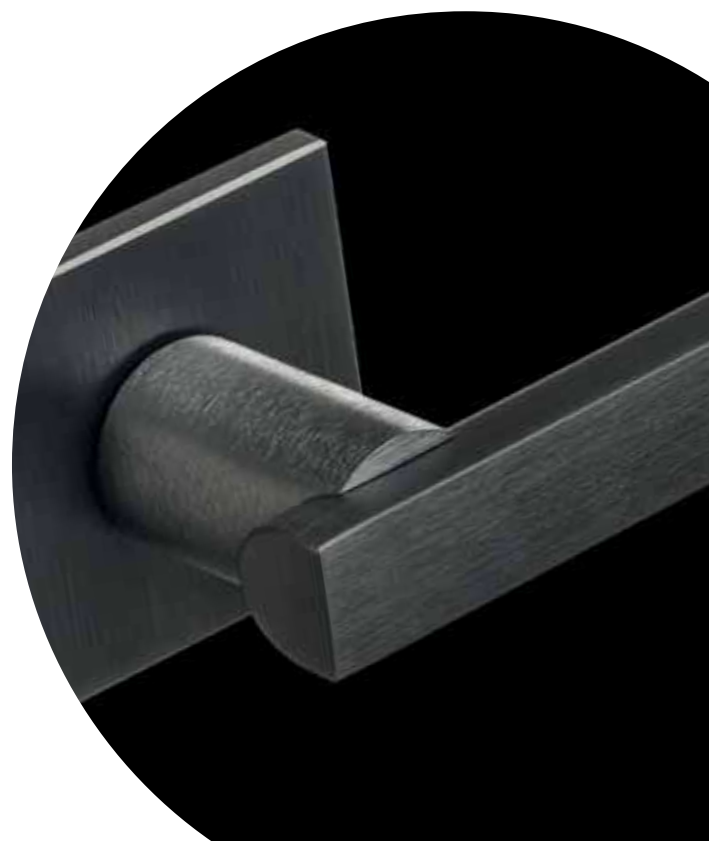
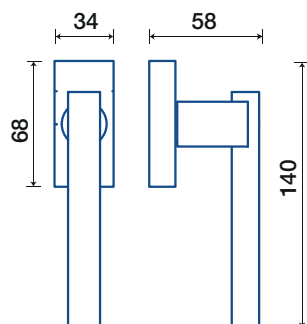

# Sweep QT



OTTONE/BRASS

ANTRACITE  
ANTRACITE



*Roberto Semprini design*



720/50 QT

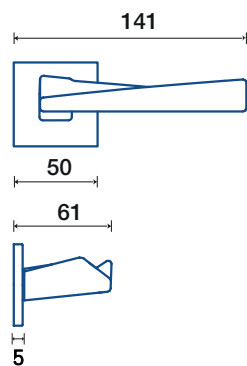

720/32 Q DK

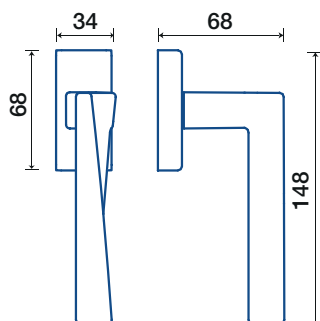



# Uovo RT



ANTRACITE  
ANTRACITE

OTTONE/BRASS



*Frascio design*



796/50 RT

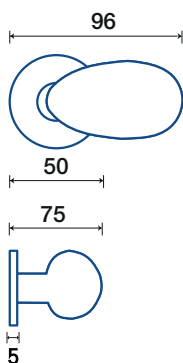

796/32 DK

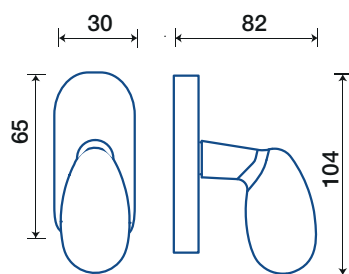

# Leaf RT



ANTRACITE  
ANTRACITE

ZAMA/ZAMAK



*Brian Sironi design*



1520/50 RT

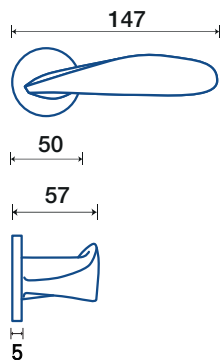

1520/32 DK

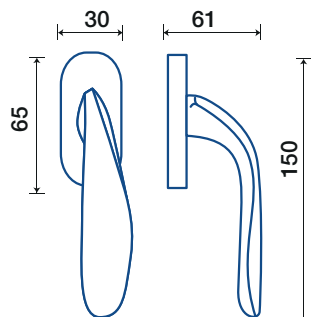





TRADIZIONALI  
TRADITIONAL

# Express

ZAMA/ZAMAK



*Frascio design*



860/51 Q

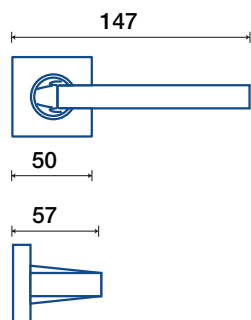

860/31 Q DK

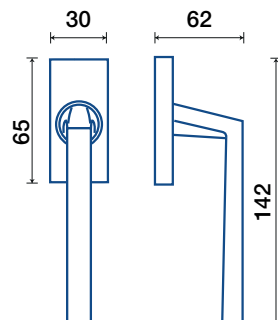

CROMO LUCIDO  
POLISHED CHROME

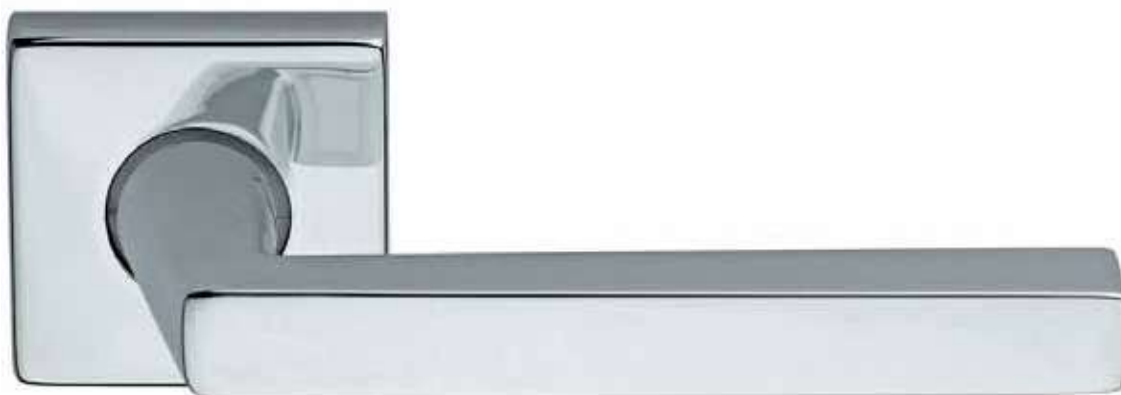

CROMO SATINATO  
SATIN CHROME



# Metro

ZAMA/ZAMAK



*Frascio design*



270/50 Q

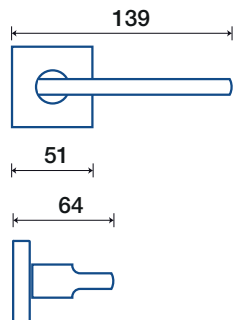

270/32 Q DK

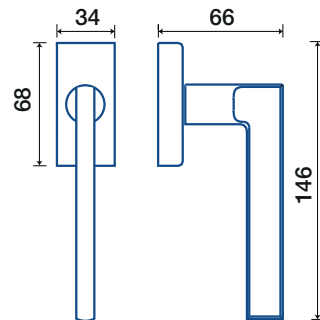

270/E 42

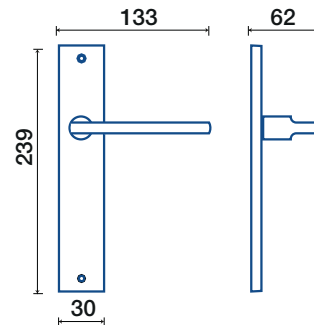

CROMO SATINATO  
POLISHED CHROME



NICKEL SATINATO  
SATIN NICKEL





# Metro Round

ZAMA/ZAMAK



*Frascio design*



270/50 I

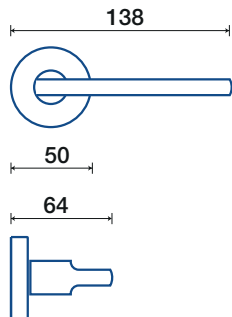

270/32 DK

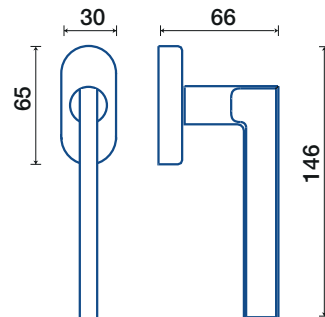

270/E 42

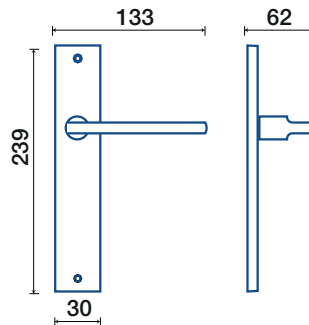

CROMO SATINATO

SATIN CHROME



NICKEL SATINATO

SATIN NICKEL



# Aton

ZAMA/ZAMAK



*Frascio design*



930/50 I

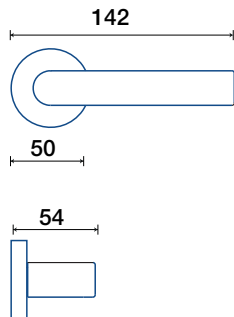

930/32 DK

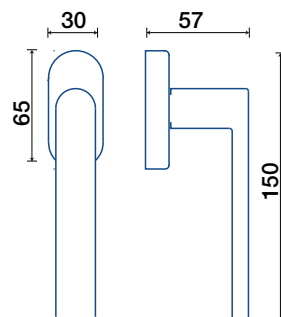

CROMO LUCIDO  
POLISHED CHROME



CROMO SATINATO  
SATIN CHROME



# Butterfly



ZAMA/ZAMAK



*Frascio design*



250/45

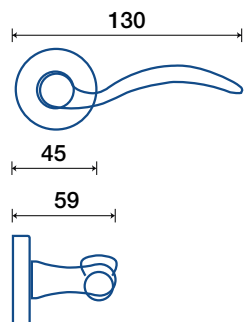

250/32 S DK

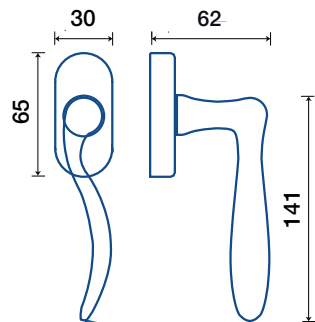

250/P 703

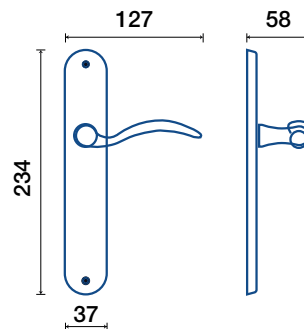

CROMO SATINATO

SATIN CHROME



INOX BRASS

INOX BRASS



# Venere

OTTONE/BRASS



*BCF design*



**309/50 I**

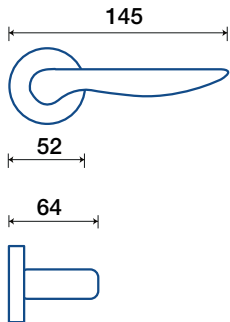

**309/32 DK**

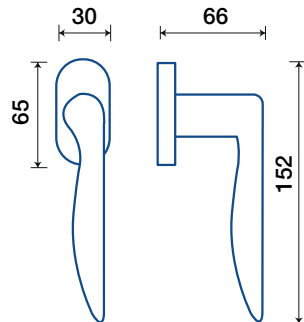

**309/30**

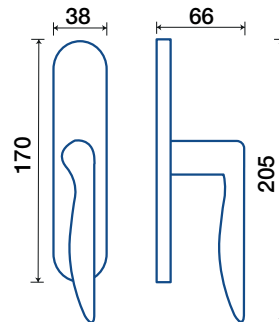

CROMO SATINATO

SATIN CHROME



OTTONE LUCIDO VERNICIATO

POLISHED BRASS

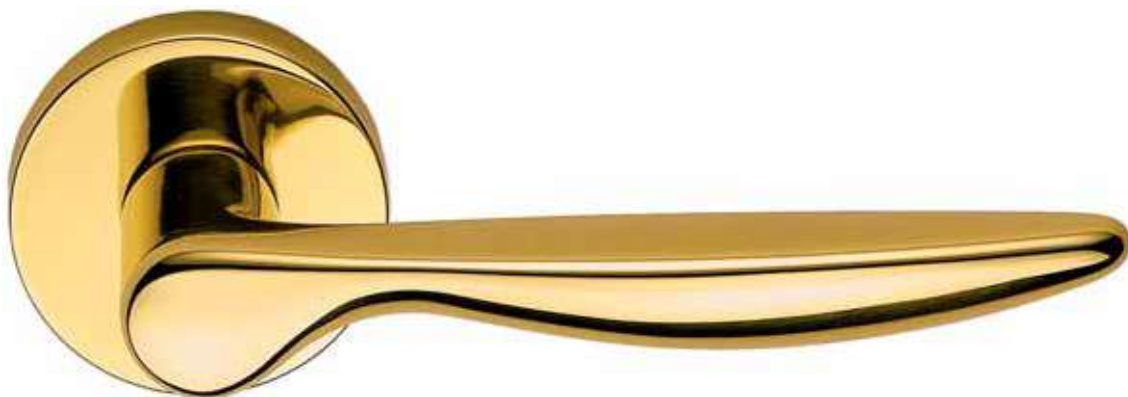



# Soft



ZAMA/ZAMAK



*BCF design*



**400/45**

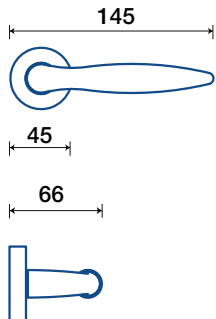

**400/32 S DK**

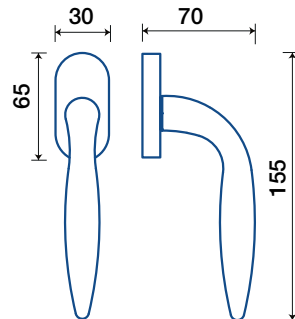

CROMO LUCIDO  
POLISHED CHROME



CROMO SATINATO  
SATIN CHROME



INOX BRASS  
INOX BRASS



INOX CHROME  
INOX CHROME



# Soft Plus

ZAMA/ZAMAK



*Frascio design*



401/45

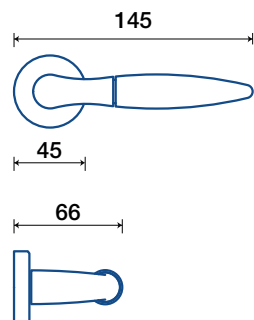

401/32 S DK

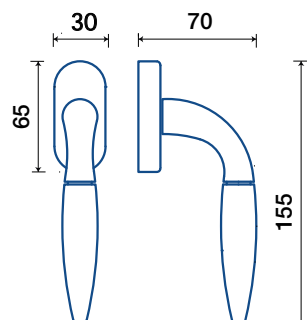

401/30

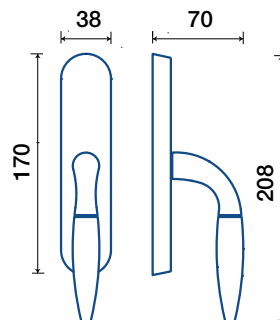

NICKEL SATINATO / NICKEL  
SATIN NICKEL / NICKEL



BI-INOX  
BI-INOX



# Nicole



ZAMA/ZAMAK



*BCF design*



**400/50 I**

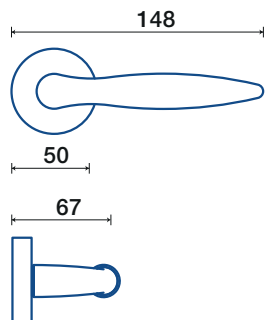

**400/32 DK**

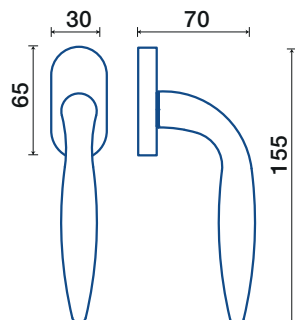

**400/30**

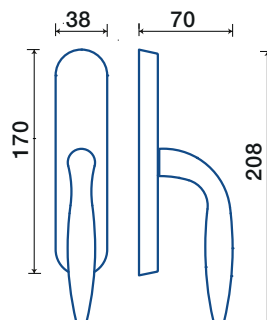

**400/P 23**

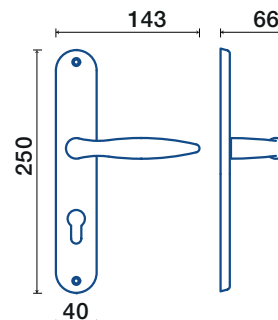

CROMO SATINATO

SATIN CHROME



ANTICO OPACO

MATT ANTIQUE BRASS



INOX BRASS

INOX BRASS



INOX CHROME

INOX CHROME



# Nicole Plus

ZAMA/ZAMAK



*Frascio design*



**401/50 I**

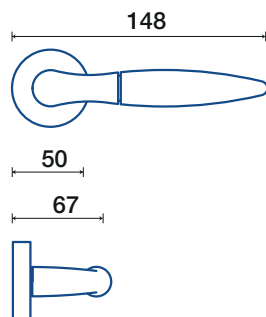

**401/32 DK**

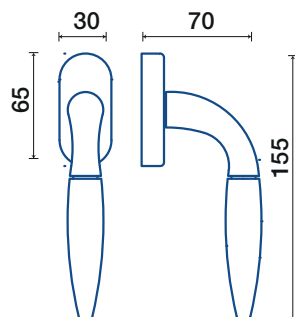

**401/30**

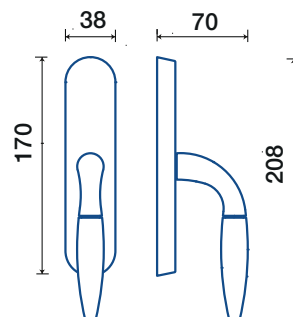

NICKEL SATINATO / NICKEL

SATIN NICKEL / NICKEL



BI-INOX

BI-INOX





# Laguna



OTTONE/BRASS



*BCF design*



**300/50 I**

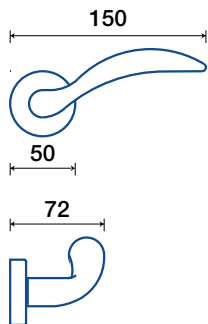

**300/32 DK**

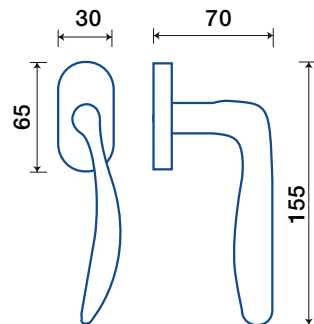

**300/30**

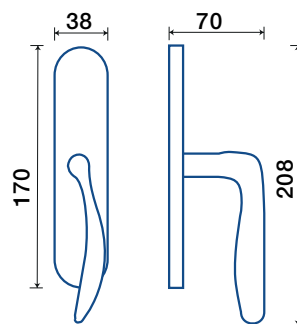

CROMO SATINATO

SATIN CHROME



ANTICO OPACO

MATT ANTIQUE BRASS



INOX BRASS

INOX BRASS



OTTONE LUCIDO VERNICIATO

POLISHED BRASS



# Euro



OTTONE/BRASS



*Frascio design*



**403/50 I**

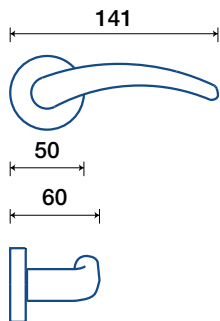

**403/32 DK**

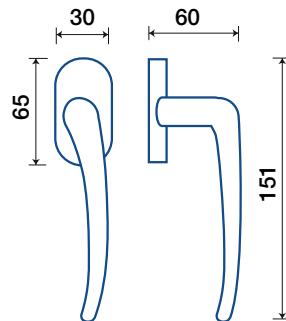

**403/30**

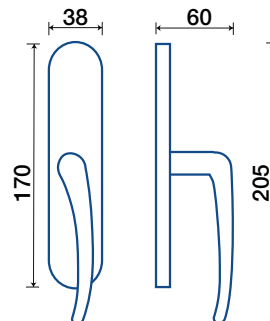

**403/P 23**

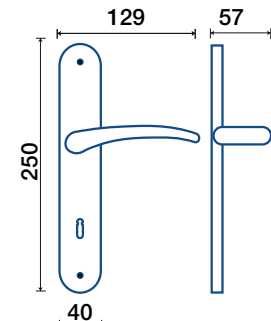

CROMO SATINATO

SATIN CHROME



ANTICO OPACO

MATT ANTIQUE BRASS



INOX BRASS

INOX BRASS



OTTONE LUCIDO VERNICIATO

POLISHED BRASS



# Uovo



OTTONE/BRASS



*Frascio design*



796/50 I

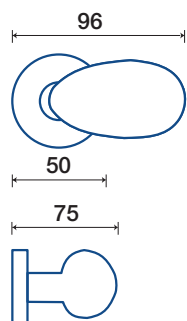

796/32 DK

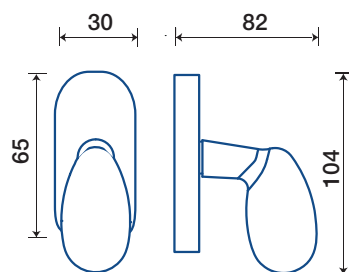

CROMO LUCIDO  
POLISHED CHROME



CROMO SATINATO  
SATIN CHROME



INOX BRASS  
INOX BRASS



OTTONE LUCIDO VERNICIATO  
POLISHED BRASS



# Apollo

OTTONE/BRASS



*Frascio design*



110/50 R

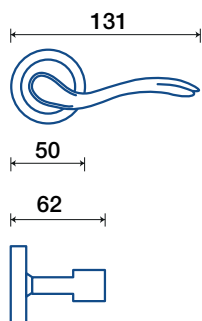

110/32 DK

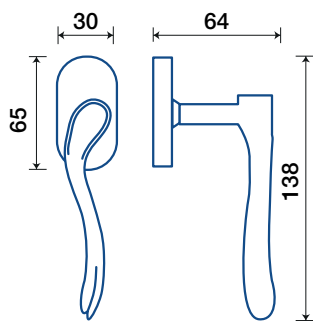

110/P 90

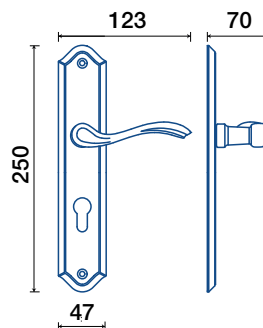



CROMO SATINATO  
SATIN CHROME



ANTICATO  
ANTICATO



BLACK IRON  
BLACK IRON



OTTONE LUCIDO VERNICIATO  
POLISHED BRASS





# Star

OTTONE/BRASS



*Frascio design*



**146/50 R**

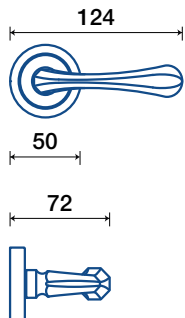

**146/32 DK**

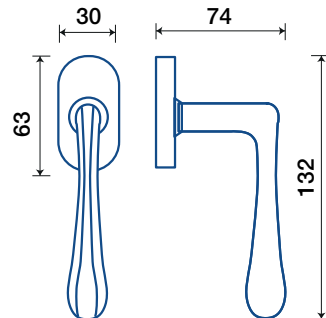

**146/P 90**

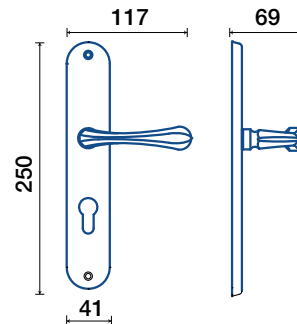

ANTICATO  
ANTICATO



BLACK IRON  
BLACK IRON



OTTONE LUCIDO VERNICIATO  
POLISHED BRASS



# Modulo L

OTTONE/BRASS



*Frascio design*



**745/50 R**

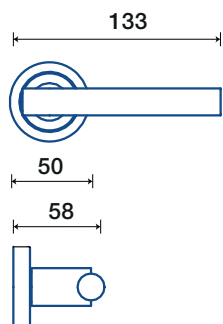

**745/32 DK**

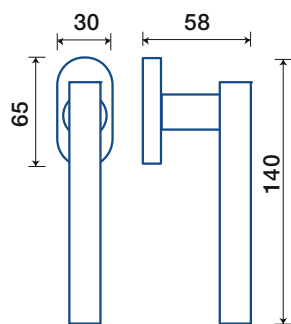

**745/30**

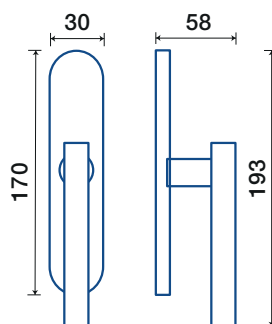

CROMO LUCIDO  
POLISHED CHROME



CROMO SATINATO  
SATIN CHROME



CROMO SATINATO/ CROMO LUCIDO  
SATIN CHROME/ POLISHED CHROME



# Easy



ZAMA/ZAMAK



*Brian Sironi design*



200/45

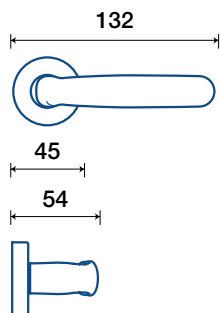

200/32 S DK

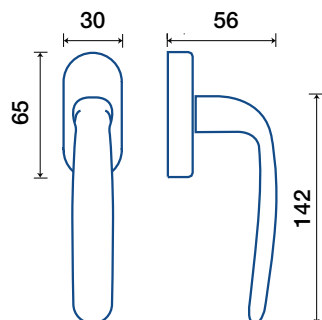

CROMO LUCIDO  
POLISHED CHROME



CROMO SATINATO  
SATIN CHROME



INOX BRASS  
INOX BRASS



# Halley

OTTONE/BRASS



*BCF design*



2250/50 R

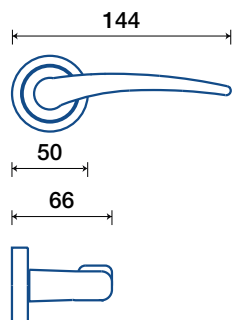

2250/32 DK

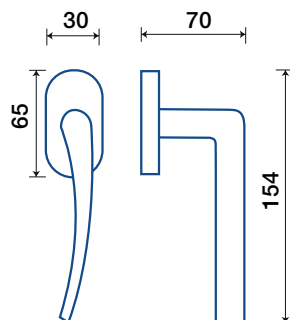

2250/30

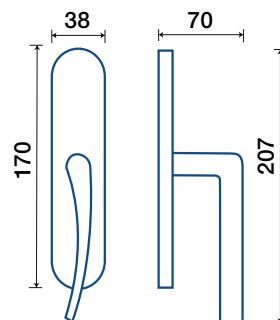

CROMO SATINATO

POLISHED CHROME



NICKEL SATINATO

SATIN NICKEL



OTTONE LUCIDO VERNICIATO

POLISHED BRASS





# 300/LP



OTTONE/BRASS



*Frascio design*

INOX BRASS - INOX BRASS  
INOX CHROME - INOX CHROME  
OTTONE LUCIDO VERNICIATO - POLISHED BRASS  
CROMO SATINATO - SATIN CHROME



300/LP

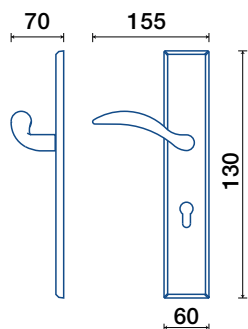

# 300/LE



OTTONE/BRASS



*Frascio design*

INOX BRASS - INOX BRASS  
INOX CHROME - INOX CHROME  
OTTONE LUCIDO VERNICIATO - POLISHED BRASS  
CROMO SATINATO - SATIN CHROME



**300/LE**

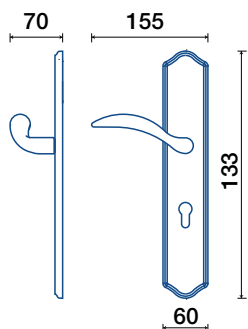

# Raffaella

ZAMA/ZAMAK



*Frascio design*

PERLA / CROMO LUCIDO  
PEARL / POLISHED CHROME



5350/50 R

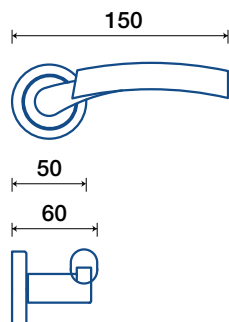

5350/32 DK

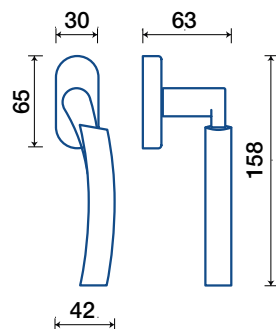

# Laura

ZAMA/ZAMAK

PERLA / CROMO LUCIDO  
PEARL / POLISHED CHROME



*Frascio design*



5550/50 R

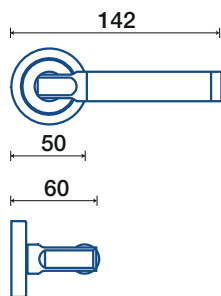

5550/32 DK

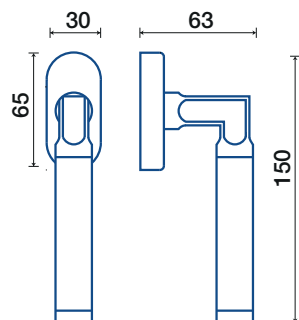

# Mimosa

CERAMICA BIANCA / OTTONE LUCIDO VERNICIATO  
WHITE CERAMIC / POLISHED BRASS

OTTONE/CERAMICA - BRASS/CERAMIC



*Frascio design*



**192/45**

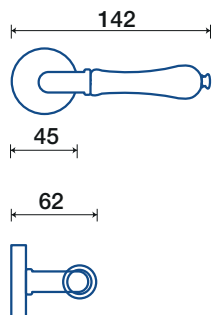

**192/32 S DK**

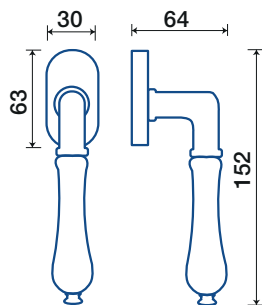

**192/P 90**

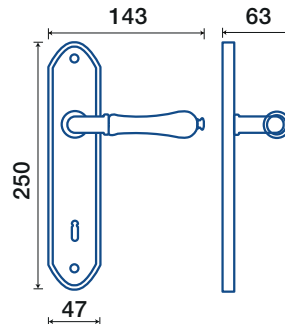

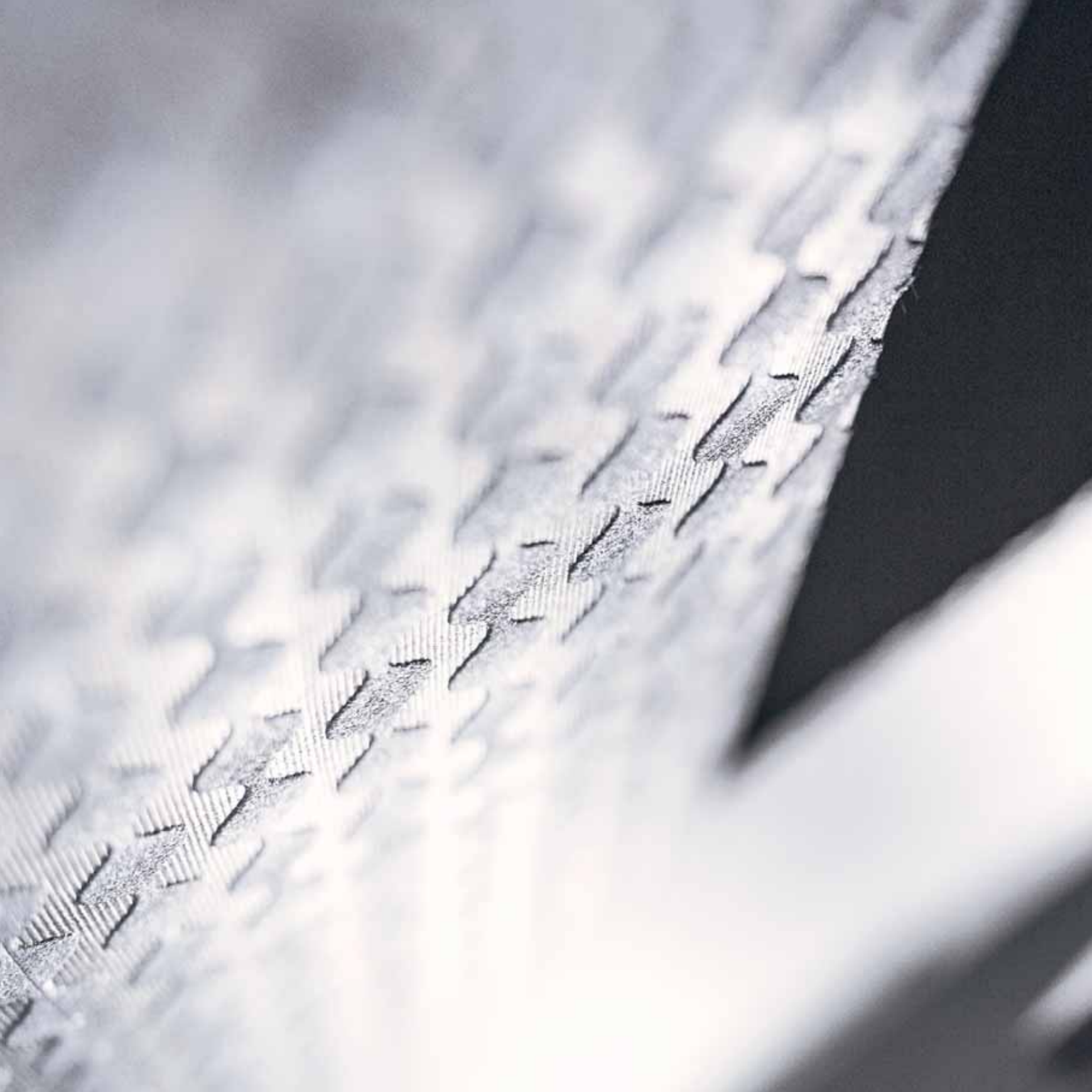



A close-up, black and white photograph of a sliding door track. The track is a dark, metallic profile with a textured surface. A handle, which appears to be a pull handle, is mounted on the track. The handle has a complex, multi-faceted design with several flat surfaces and rounded edges. The lighting is dramatic, coming from the upper right, creating a bright highlight on the top edge of the track and casting deep shadows in the recessed areas of the handle and track. The background is dark and out of focus.

**KIT PORTE SCORREVOLI,  
POMOLI E ACCESSORI  
SLIDING DOOR HANDLES,  
PULL HANDLES E ACCESSORIES**

# A Coppia nicchie tonde con o senza foro chiave



COPPIA NICCHIE TONDE  
CON O SENZA FORO CHIAVE,  
SENZA SERRATURA,  
SENZA MANIGLIETTA DI  
TRASCINAMENTO

SLIDING DOOR HANDLE BLIND OR  
KEY HOLE, WITHOUT LOCK AND  
FINGER PULL

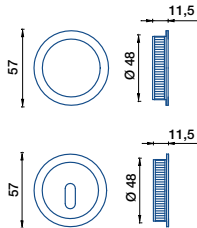

## FINITURE/FINISHES

OTTONE LUCIDO VERNICIATO  
POLISHED BRASS  
CROMO LUCIDO  
POLISHED CHROME  
CROMO SATINATO  
SATIN CHROME  
BRONZO  
BRONZE  
BIANCO  
WHITE  
LONDON NIGHT LUCIDO  
LONDON NIGHT POLISHED  
LONDON NIGHT SATINATO  
LONDON NIGHT SATIN  
RED COPPER LUCIDO  
RED COPPER POLISHED  
RED COPPER SATINATO  
RED COPPER SATIN  
GREY STONE  
GREY STONE  
ANTRACITE  
ANTRACITE

# B Kit n° 0 con foro chiave

KIT CON CHIAVE SNODATA,  
SERRATURA ENTRATA 50 mm  
E MANIGLIETTA  
DI TRASCINAMENTO

SLIDING DOOR HANDLE WITH  
FLEXIBLE KEY, LOCK 50 mm BKS  
AND FINGER PULL

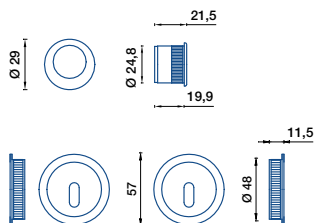



# C Kit n° 7

**KIT SENZA FORO CHIAVE, SENZA  
SERRATURA, CON MANIGLIETTA  
DI TRASCINAMENTO**

BLIND SLIDING DOOR HANDLE  
WITHOUT LOCK, WITH FINGER PULL

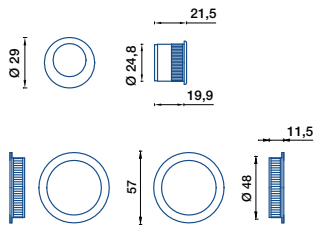

## FINITURE/FINISHES

OTTONE LUCIDO VERNICIATO  
POLISHED BRASS  
CROMO LUCIDO  
POLISHED CHROME  
CROMO SATINATO  
SATIN CHROME  
BRONZO  
BRONZE  
BIANCO  
WHITE  
LONDON NIGHT LUCIDO  
LONDON NIGHT POLISHED  
LONDON NIGHT SATINATO  
LONDON NIGHT SATIN  
RED COPPER LUCIDO  
RED COPPER POLISHED  
RED COPPER SATINATO  
RED COPPER SATIN  
GREY STONE  
GREY STONE  
ANTRACITE  
ANTRACITE

# E Kit n° 0

**KIT A SCOMPARSA TOTALE CON  
SERRATURA ENTRATA  
50 mm E MANIGLIETTA  
DI TRASCINAMENTO**

SLIDING DOOR HANDLE WITH LOCK  
50 mm BKS AND FINGER PULL

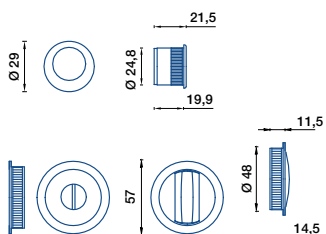

# D Coppia nicchie tonde alte

**COPPIA NICCHIE TONDE ALTE  
SENZA FORO CHIAVE E SENZA  
SERRATURA**

BLIND SLIDING DOOR HANDLE  
WITHOUT LOCK

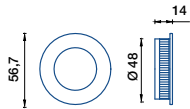

# O-MT 48

**DOPPIO ANELLO SENZA  
SERRATURA**

SLIDING DOOR HANDLE WITH  
DOUBLE RING TURN W/OUT LOCK

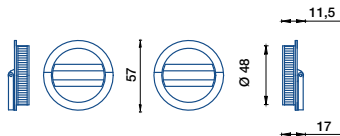

**FINITURE/FINISHES**

OTTONE LUCIDO VERNICIATO

POLISHED BRASS

CROMO LUCIDO

POLISHED CHROME

CROMO SATINATO

SATIN CHROME

BRONZO

BRONZE

# P-MM 48

**ANELLO + VITE SENZA  
SERRATURA**

SLIDING DOOR HANDLE WITH  
RING AND RELEASE W/OUT LOCK

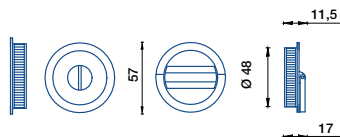

# F Kit n° 1

**KIT A SCOMPARSA TOTALE CON  
SERRATURA ENTRATA 50 mm E  
MANIGLIETTA DI TRASCINAMENTO**

SLIDING DOOR HANDLE WITH LOCK  
50 mm BKS AND FINGER PULL

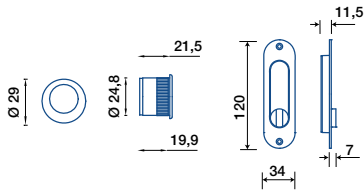

# H Kit n° 3

**KIT CON CHIAVE SNODATA CON  
SERRATURA ENTRATA 50 mm E  
MANIGLIETTA DI TRASCINAMENTO**

SLIDING DOOR HANDLE WITH FLEXIBLE  
KEY, LOCK 50 mm BKS  
AND FINGER PULL

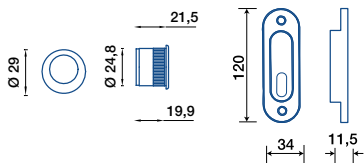

# I Kit n° 4

**KIT SENZA FORO CHIAVE, SENZA  
SERRATURA, CON MANIGLIETTA  
DI TRASCINAMENTO**

BLIND SLIDING DOOR HANDLE,  
WITH FINGER PULL

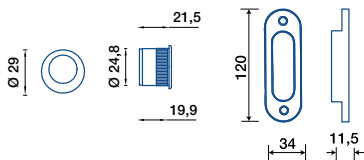

## FINITURE/FINISHES

OTTONE LUCIDO VERNICIATO

POLISHED BRASS

CROMO LUCIDO

POLISHED CHROME

CROMO SATINATO

SATIN CHROME

BRONZO

BRONZE

# R Kit quadrato con foro chiave

**KIT QUADRATO CON CHIAVE  
SNODATA, CON SERRATURA  
ENTRATA 50 mm E MANIGLIETTA  
DI TRASCINAMENTO**

SLIDING DOOR HANDLE WITH  
FLEXIBLE KEY, LOCK 50 mm BKS  
AND FINGER PULL

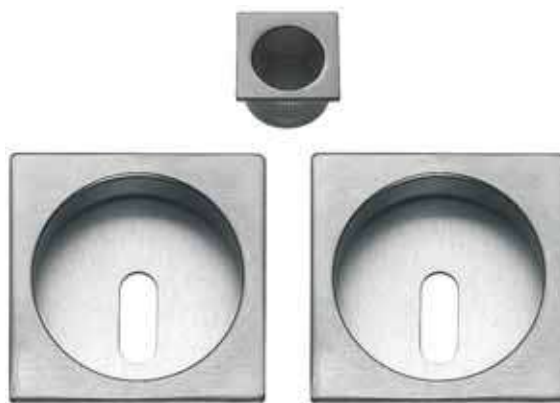
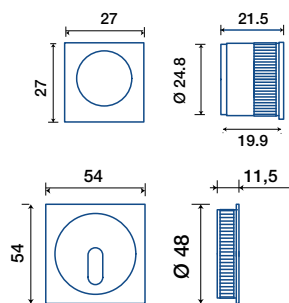

**FINITURE/FINISHES**

**OTTONE LUCIDO VERNICIATO**

**POLISHED BRASS**

**CROMO LUCIDO**

**POLISHED CHROME**

**CROMO SATINATO**

**SATIN CHROME**

**BRONZO TREND**

**BRONZE TREND**

**BIANCO**

**WHITE**

**LONDON NIGHT LUCIDO**

**LONDON NIGHT POLISHED**

**LONDON NIGHT SATINATO**

**LONDON NIGHT SATIN**

**RED COPPER LUCIDO**

**RED COPPER POLISHED**

**RED COPPER SATINATO**

**RED COPPER SATIN**

**GREY STONE**

**GREY STONE**

**ANTRACITE**

**ANTRACITE**

**NERO OPACO**

**MATT BLACK**

**CORTEN**

**CORTEN**

**CRACKLÉ**

**CRACKLÉ**

**LEATHER**

**LEATHER**

**OSSIDATO**

**OSSIDATO**

# S Kit n° 8 quadrato

**KIT QUADRATO SENZA FORO  
CHIAVE, SENZA SERRATURA,  
CON MANIGLIETTA DI  
TRASCINAMENTO**

BLIND SLIDING DOOR HANDLE  
WITHOUT LOCK, WITH FINGER PULL

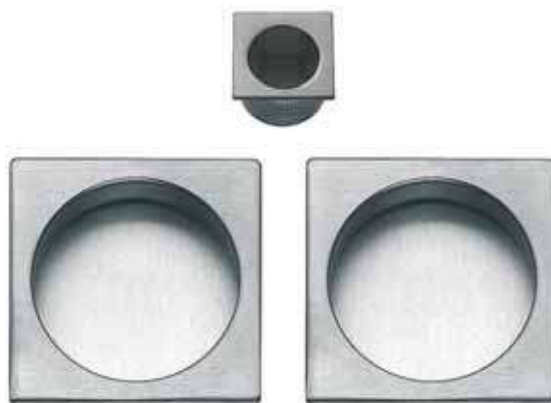
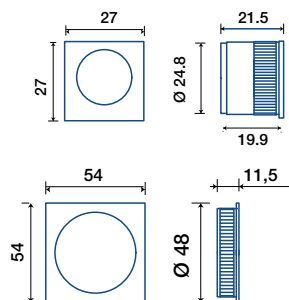

# Q Coppia nicchie quadrate con o senza foro

**COPPIA NICCHIE QUADRATE  
CON O SENZA FORO CHIAVE,  
SENZA SERRATURA,  
SENZA MANIGLIETTA DI  
TRASCINAMENTO**

SLIDING DOOR HANDLE BLIND OR  
KEY HOLE WITHOUT LOCK AND  
FINGER PULL

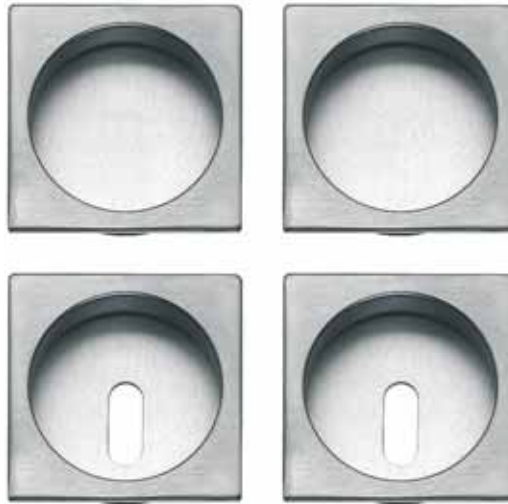
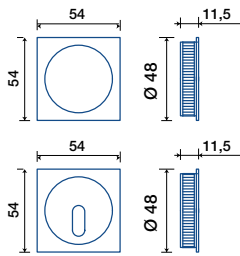

## FINITURE/FINISHES

OTTONE LUCIDO VERNICIATO  
POLISHED BRASS  
CROMO LUCIDO  
POLISHED CHROME  
CROMO SATINATO  
SATIN CHROME  
BRONZO TREND  
BRONZE TREND  
BIANCO  
WHITE  
LONDON NIGHT LUCIDO  
LONDON NIGHT POLISHED  
LONDON NIGHT SATINATO  
LONDON NIGHT SATIN  
RED COPPER LUCIDO  
RED COPPER POLISHED  
RED COPPER SATINATO  
RED COPPER SATIN  
GREY STONE  
GREY STONE  
ANTRACITE  
ANTRACITE  
NERO OPACO  
MATT BLACK  
BIANCO  
WHITE  
CORTEN  
CORTEN  
CRACKLÉ  
CRACKLÉ  
LEATHER  
LEATHER  
OSSIDATO  
OSSIDATO

# T Kit n° 9 quadrato

**KIT QUADRATO A SCOMPARSITA'  
TOTALE CON SERRATURA  
ENTRATA 50 mm E MANIGLIETTA  
DI TRASCINAMENTO**

SLIDING DOOR HANDLE WITH LOCK  
50 mm BKS AND FINGER PULL

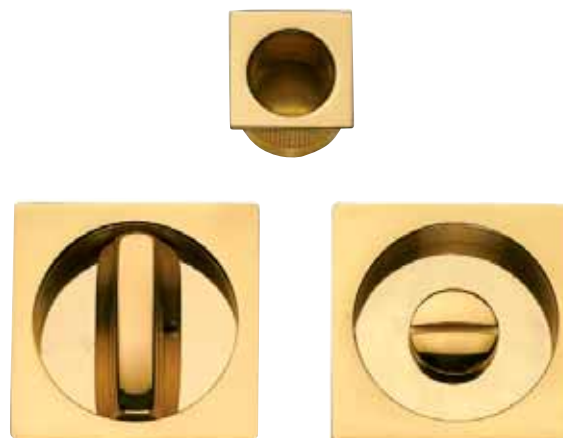
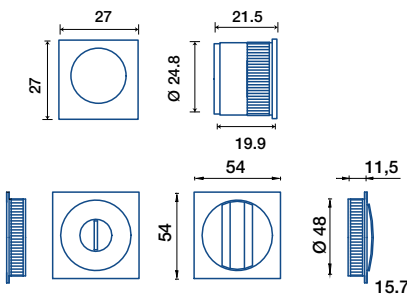

# Coppia nicchie con mezzaluna

AA



**COPPIA NICCHIE TONDE  
CON MEZZALUNA**

ROUND SLIDING DOOR HANDLE  
WITH HALF MOON

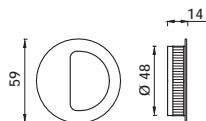

QB



**COPPIA NICCHIE QUADRATE  
CON MEZZALUNA**

SQUARE SLIDING DOOR HANDLE  
WITH HALF MOON

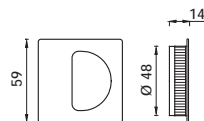

## FINITURE/FINISHES

OTTONE LUCIDO VERNICIATO  
POLISHED BRASS  
CROMO LUCIDO  
POLISHED CHROME  
CROMO SATINATO  
SATIN CHROME

L



**MANIGLIETTA DI  
TRASCINAMENTO TONDA**

ROUND FINGER PULL

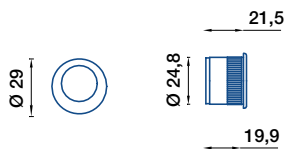

V



**MANIGLIETTA DI  
TRASCINAMENTO QUADRATA**

SQUARE FINGER PULL

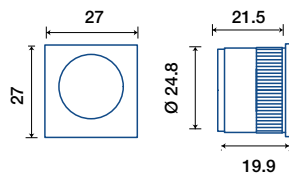

## FINITURE/FINISHES

OTTONE LUCIDO VERNICIATO  
POLISHED BRASS  
CROMO LUCIDO  
POLISHED CHROME  
CROMO SATINATO  
SATIN CHROME  
BRONZO  
BRONZE  
BIANCO  
WHITE  
LONDON NIGHT LUCIDO  
LONDON NIGHT POLISHED  
LONDON NIGHT SATINATO  
LONDON NIGHT SATIN  
RED COPPER LUCIDO  
RED COPPER POLISHED  
RED COPPER SATINATO  
RED COPPER SATIN  
GREY STONE  
GREY STONE  
ANTRACITE  
ANTRACITE

# Serratura per porte scorrevoli

SERRATURA PORTE SCORREVOLI  
CON QUADRO, ENTRATA 50 mm,  
FRONTALE 16 mm

SLIDING DOOR LOCK  
WITH SQUARE HOLE,  
50 mm BKS, 16 mm FACEPLATE

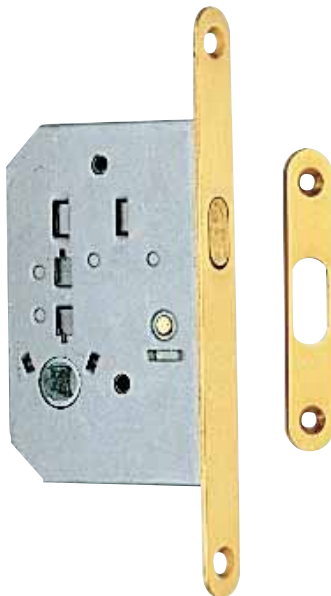

## FINITURE/FINISHES

OTTONE LUCIDO VERNICIATO  
POLISHED BRASS  
CROMO LUCIDO  
POLISHED CHROME  
CROMO SATINATO  
SATIN CHROME  
BRONZO  
BRONZE

# Serratura per porte scorrevoli con chiave snodata

SERRATURA PORTE SCORREVOLI  
CON CHIAVE SNODATA, ENTRATA  
50 mm, FRONTALE 16 mm

SLIDING DOOR LOCK WITH KEY  
HOLE, 50 mm BKS, 16 mm  
FACEPLATE

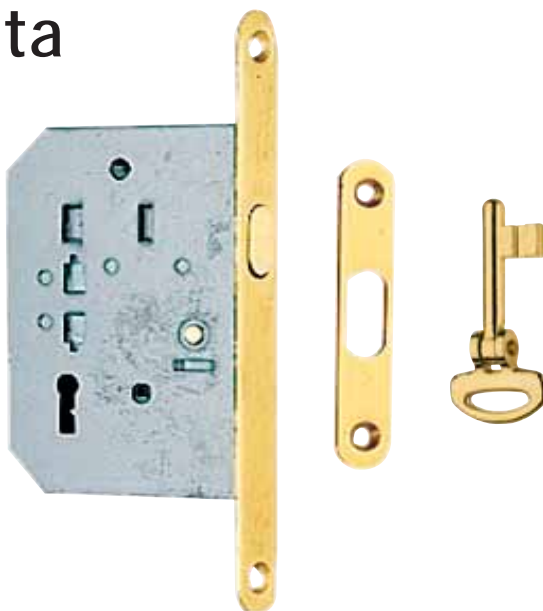



# Frontale gaccia

FRONTALE GACCIA CON  
O SENZA FORO

FRONT GACCIA WITH OR  
WITHOUT HOLE

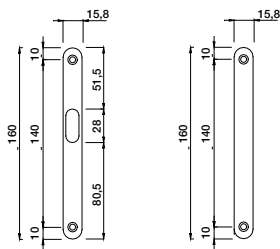

## FINITURE/FINISHES

OTTONE LUCIDO VERNICIATO  
POLISHED BRASS  
CROMO LUCIDO  
POLISHED CHROME  
CROMO SATINATO  
SATIN CHROME  
BRONZO  
BRONZE

# Nicchia 981

NICCHIA CON O SENZA FORO  
CHIAVE

SLIDING DOOR HANDLE WITH OR  
WITHOUT KEY HOLE

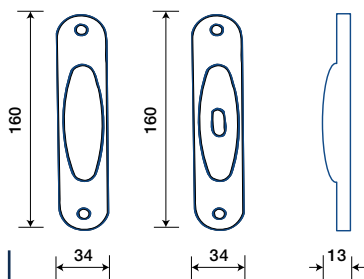

## FINITURE/FINISHES

OTTONE LUCIDO VERNICIATO  
POLISHED BRASS  
CROMO LUCIDO  
POLISHED CHROME  
CROMO SATINATO  
SATIN CHROME



# Nicchia 800

**NICCHIA CON O SENZA FORO  
CHIAVE**

SLIDING DOOR HANDLE WITH OR  
WITHOUT KEY HOLE

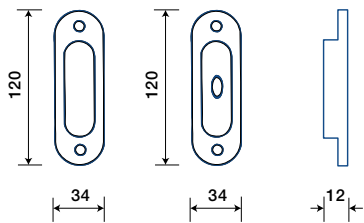

## FINITURE/FINISHES

OTTONE LUCIDO VERNICIATO  
POLISHED BRASS  
CROMO LUCIDO  
POLISHED CHROME  
CROMO SATINATO  
SATIN CHROME

# Nicchia 780

**NICCHIA CON O SENZA FORO  
CHIAVE**

SLIDING DOOR HANDLE WITH OR  
WITHOUT KEY HOLE

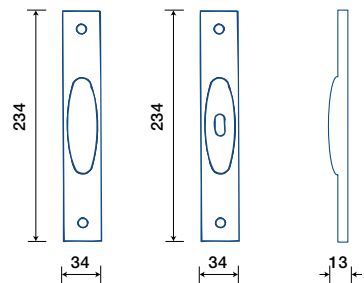

## FINITURE/FINISHES

OTTONE LUCIDO VERNICIATO  
POLISHED BRASS  
CROMO LUCIDO  
POLISHED CHROME  
CROMO SATINATO  
SATIN CHROME

# Siena



OTTONE/BRASS

## FINITURE/FINISHES

CROMO SATINATO  
SATIN CHROME  
NICKEL SATINATO  
SATIN NICKEL  
ANTRACITE  
ANTRACITE



*Frascio design*



### 5041

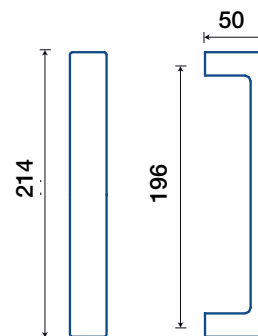

### 5041 UG

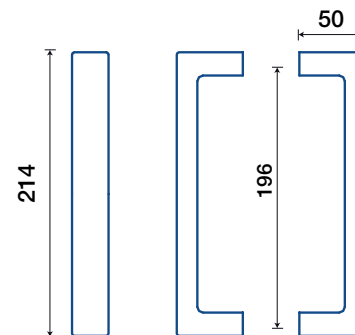

# Tuke Glass



*Brian Sironi design*



OTTONE/BRASS

FINITURE/FINISHES

CROMO LUCIDO  
POLISHED CHROME  
CROMO SATINATO  
SATIN CHROME

629

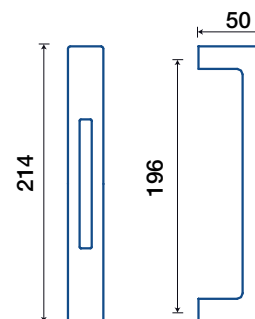

629 UG

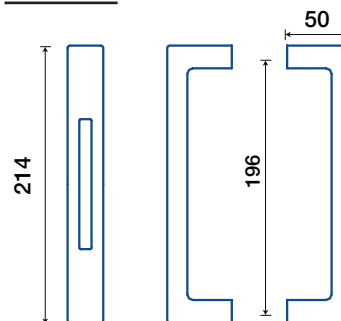

# Pisa



OTTONE/BRASS

FINITURE/FINISHES

INOX BRASS  
INOX BRASS  
CROMO LUCIDO  
POLISHED CHROME  
CROMO SATINATO  
SATIN CHROME

5042

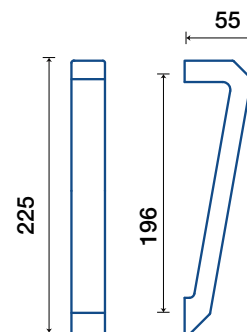

5042 UG

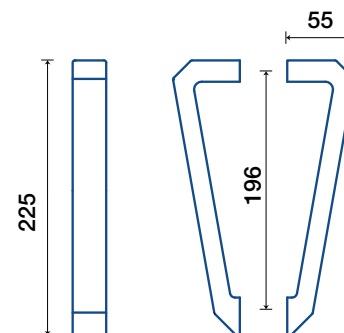

*Frascio design*

# Kalè



*Frascio design*

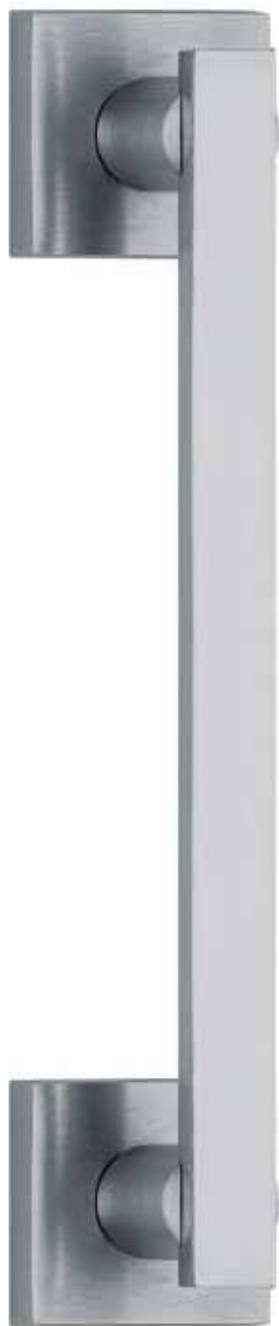

OTTONE/BRASS

FINITURE/FINISHES

CROMO LUCIDO  
POLISHED CHROME  
CROMO SATINATO  
SATIN CHROME  
CROMO SATINATO / LUCIDO  
SATIN / POLISHED CHROME

**651**

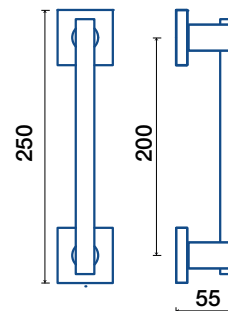

**651 UG**

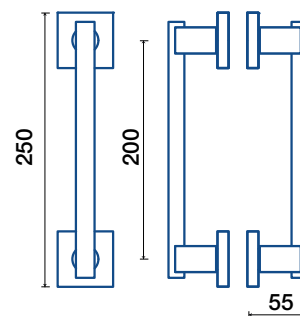

# Modulo L

OTTONE/BRASS

FINITURE/FINISHES

CROMO LUCIDO  
POLISHED CHROME  
CROMO SATINATO  
SATIN CHROME  
CROMO SATINATO / LUCIDO  
SATIN / POLISHED CHROME



*Frascio design*



**792**

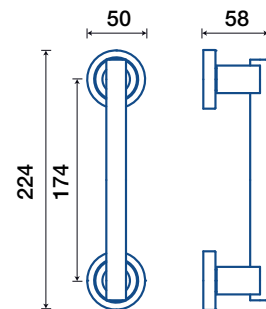

**792 UG**

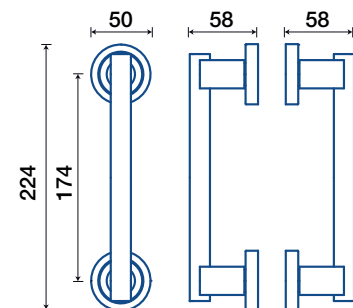

# Ibis



*Giulio Iacchetti design*



OTTONE/BRASS

FINITURE/FINISHES

INOX BRASS  
INOX BRASS  
OTTONE LUCIDO VERNICIATO  
POLISHED BRASS  
CROMO SATINATO  
SATIN CHROME  
ANTRACITE  
ANTRACITE

**501**

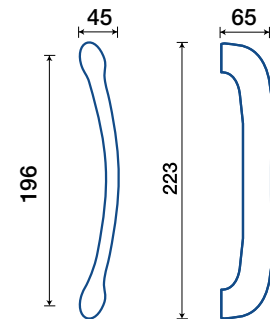

**501 UG**

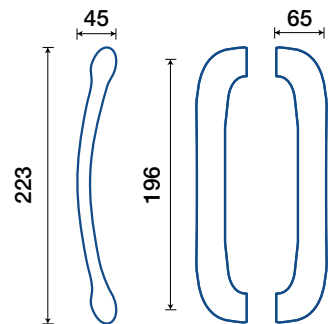

# Easy



ZAMA/ZAMAK

FINITURE/FINISHES

INOX BRASS  
INOX BRASS  
CROMO LUCIDO  
POLISHED CHROME  
CROMO SATINATO  
SATIN CHROME

**201**

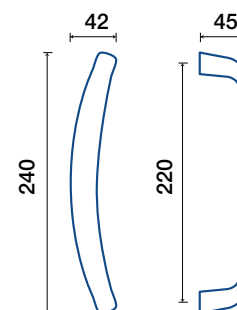

**201 UG**

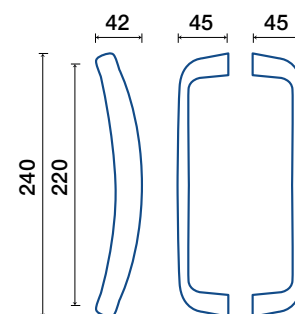

*Frascio design*





# 934



*Frascio design*



OTTONE/ACCIAIO

BRASS/STAINLESS STEEL

FINITURE/FINISHES

BI - INOX

BI - INOX

ACCIAIO SATINATO / CROMO LUCIDO

SATIN STAINLESS STEEL / POLISHED CHROME

934

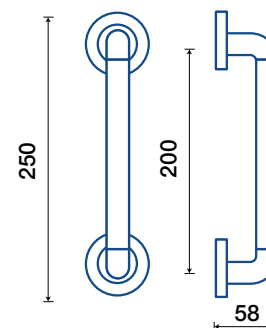

934 UG

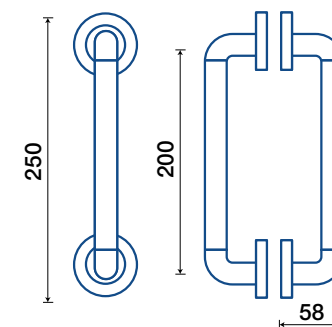

# Pavone



OTTONE/BRASS

## FINITURE/FINISHES

INOX BRASS  
INOX BRASS  
OTTONE LUCIDO VERNICIATO  
POLISHED BRASS  
CROMO SATINATO  
SATIN CHROME  
ANTRACITE  
ANTRACITE

**506**

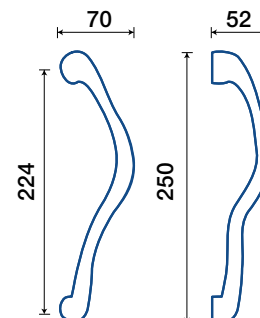

**506 UG**

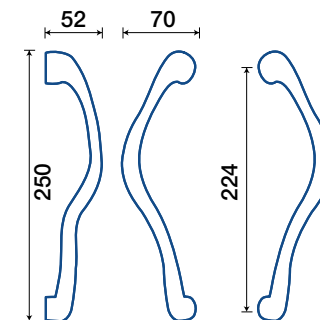

*Controdesign design*



# Fenice



OTTONE/BRASS

FINITURE/FINISHES

INOX BRASS  
INOX BRASS  
OTTONE LUCIDO VERNICIATO  
POLISHED BRASS  
CROMO SATINATO  
SATIN CHROME  
ANTRACITE  
ANTRACITE



*Marcello Ziliani design*



**504**

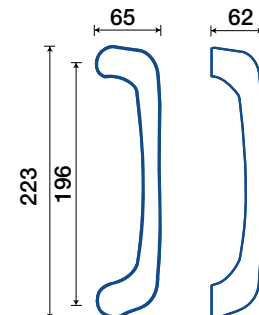

**504 UG**

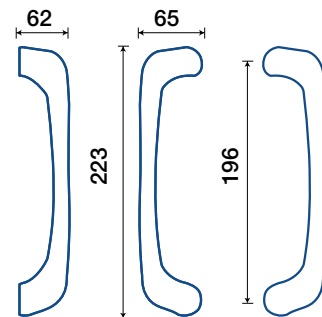

# Star



*Frascio design*



OTTONE/BRASS

FINITURE/FINISHES

OTTONE LUCIDO VERNICIATO  
POLISHED BRASS

146/92

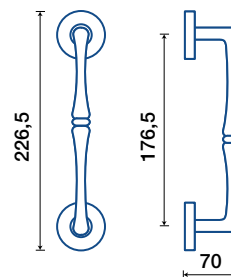

146/92 UG

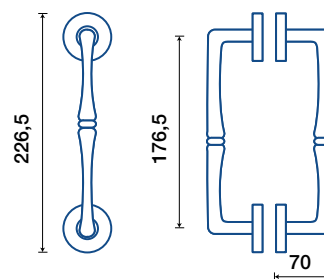

# Attila



*Frascio design*



OTTONE/BRASS

FINITURE/FINISHES

OTTONE LUCIDO VERNICIATO

POLISHED BRASS

BLACK IRON

BLACK IRON

ANTICATO

ANTICATO

**666**

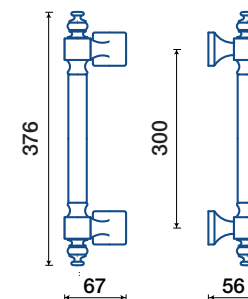

**666 UG**

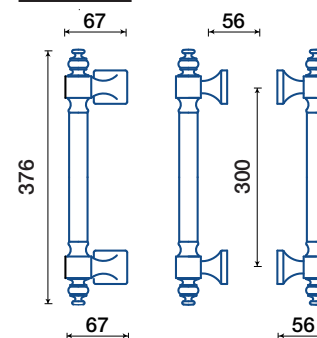

# Arpa



OTTONE/BRASS

FINITURE/FINISHES

INOX BRASS  
INOX BRASS  
INOX CHROME  
INOX CHROME



*BCF design*



**350**

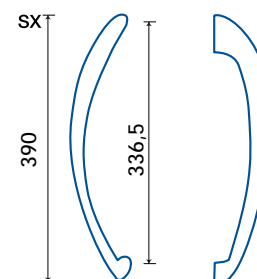

**350 UG**

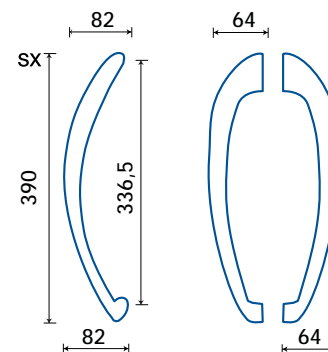

# Join QT



OTTONE / ACRILICO - BRASS / ACRYLIC

## FINITURE/FINISHES

CROMO LUCIDO  
POLISHED CHROME  
CROMO SATINATO  
SATIN CHROME  
ACCIAIO LUCIDO / CROMO SATINATO  
POLISHED STAINLESS STEEL / SATIN CHROME  
ACCIAIO SATINATO / CROMO LUCIDO  
SATIN STAINLESS STEEL / POLISHED CHROME  
ANTRACITE  
ANTRACITE

COLORI ACRILICO:  
ACRYLIC COLOURS:  
GHOST  
BLANC  
DARK  
PEPPER



*Giacomo Giustizieri design*



## 926 / 50 QT

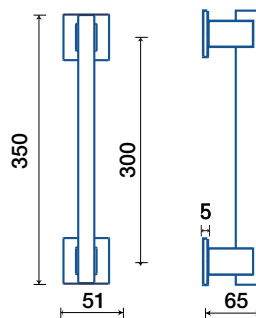

## 926 / 50 QT UG

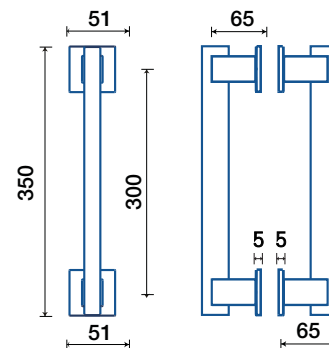

# Alzante scorrevole

## Pull-up handle for sliding door



OTTONE/BRASS

### FINITURE/FINISHES

INOX BRASS  
INOX BRASS  
OTTONE LUCIDO VERNICIATO  
POLISHED BRASS  
CROMO SATINATO  
SATIN CHROME  
ANTRACITE  
ANTRACITE

**550**

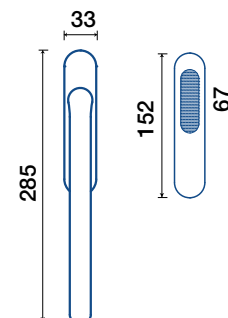

**550 UG**

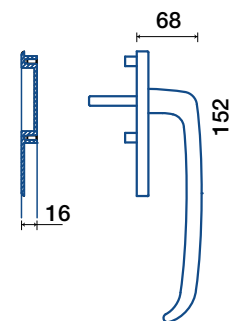

*Frascio design*





# Alzante scorrevole

## Pull-up handle for sliding door



OTTONE/BRASS



*Frascio design*



### FINITURE/FINISHES

CROMO LUCIDO  
POLISHED CHROME  
CROMO SATINATO  
SATIN CHROME  
ANTRACITE  
ANTRACITE

### 550 Q

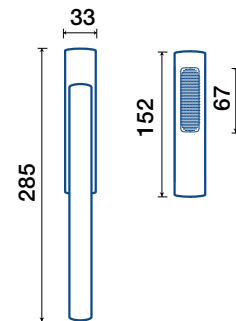

### 550 Q UG

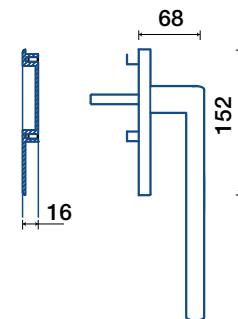

# 755



Frascio design

755 / 50 Q

POMOLO FISSO 55 x 55 mm  
SINGLE KNOB 55 x 55 mm

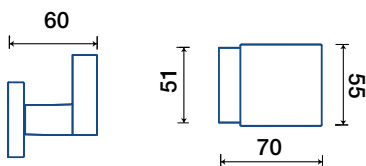

OTTONE/BRASS

FINITURE/FINISHES

CROMO LUCIDO / POLISHED CHROME  
CROMO SATINATO / SATIN CHROME  
NICKEL SATINATO / SATIN NICKEL  
BIANCO / WHITE  
BRONZO TREND / BRONZE TREND  
LONDON NIGHT LUCIDO  
LONDON NIGHT POLISHED  
LONDON NIGHT SATINATO  
LONDON NIGHT SATIN  
RED COPPER LUCIDO / RED COPPER POLISHED  
RED COPPER SATINATO / RED COPPER SATIN  
GREY STONE / GREY STONE  
NERO OPACO / MATT BLACK  
OSSIDATO / OSSIDATO  
CORTEN / CORTEN  
LEATHER / LEATHER  
CRACKLÉ / CRACKLÉ  
ANTRACITE / ANTRACITE

# Tuke Glass



Frascio design

756 / 50 Q

POMOLO FISSO 55 x 55 mm  
SINGLE KNOB 55 x 55 mm

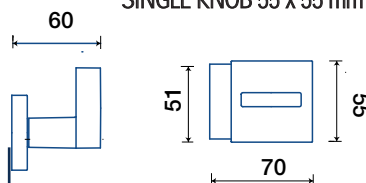

OTTONE/BRASS

FINITURE/FINISHES

CROMO LUCIDO  
POLISHED CHROME  
CROMO SATINATO  
SATIN CHROME



# 507 coppia



Frascio design

507 / 50 I

COPPIA POMOLI CON ROSETTA E  
BOCCHETTA  
SET KNOBS WITH ROSE AND  
ESCUTCHEON

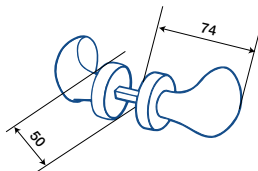

OTTONE/BRASS

## FINITURE/FINISHES

INOX BRASS  
INOX BRASS  
INOX CHROME  
INOX CHROME  
OTTONE LUCIDO VERNICIATO  
POLISHED BRASS  
CROMO LUCIDO  
POLISHED CHROME  
CROMO SATINATO  
SATIN CHROME  
NICKEL SATINATO  
SATIN NICKEL  
ANTICATO  
ANTICATO

# 507



Frascio design

507 / 50 I

POMOLO FISSO  
SINGLE KNOB

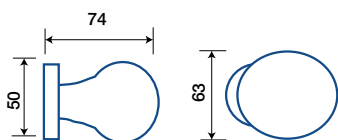

OTTONE/BRASS

## FINITURE/FINISHES

INOX BRASS / INOX BRASS  
INOX CHROME / INOX CHROME  
OTTONE LUCIDO VERNIC. / POLISHED BRASS  
CROMO LUCIDO / POLISHED CHROME  
CROMO SATINATO / SATIN CHROME  
NICKEL SATINATO / SATIN NICKEL  
ANTICO OPACO / MATT ANTIQUE BRASS  
LONDON NIGHT LUCIDO  
LONDON NIGHT POLISHED  
LONDON NIGHT SATINATO  
LONDON NIGHT SATIN  
RED COPPER LUCIDO / RED COPPER POLISHED  
RED COPPER SATINATO / RED COPPER SATIN  
GREY STONE / GREY STONE  
ANTRACITE / ANTRACITE

# 788 coppia



*Frascio design*

COPPIA POMOLI  
CON ROSETTA E BOCCHETTA  
SET KNOBS WITH ROSE AND  
ESCUTCHEON

788 - 60 / 50 I - Ø 60 mm  
788 - 50 / 50 I - Ø 50 mm

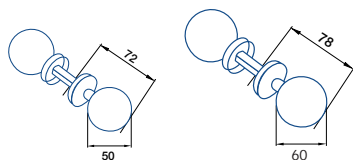

OTTONE/BRASS

FINITURE/FINISHES

INOX BRASS  
INOX BRASS  
OTTONE LUCIDO VERNICIATO  
POLISHED BRASS  
CROMO LUCIDO  
POLISHED CHROME  
CROMO SATINATO  
SATIN CHROME

# 788



*Frascio design*

POMOLI FISSO/FIXED KNOB

788 - 70 / 50 I - Ø 70 mm  
788 - 60 / 50 I - Ø 60 mm  
788 - 50 / 50 I - Ø 50 mm

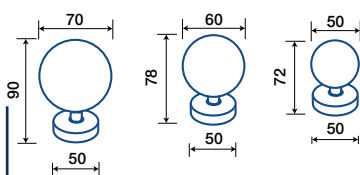

# 851



*Frascio design*

851 / 50 I  
POMOLI FISSO Ø 70 mm  
SINGLE KNOB Ø 70 mm

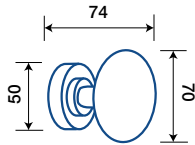

OTTONE/BRASS

FINITURE/FINISHES

OTTONE LUCIDO VERNICIATO  
POLISHED BRASS  
CROMO SATINATO  
SATIN CHROME

# Easy



*Frascio design*

760  
POMOLO FISSO  
SINGLE KNOB

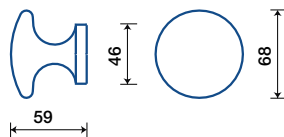

ZAMA/ZAMAK

FINITURE/FINISHES

INOX BRASS  
INOX BRASS  
CROMO LUCIDO  
POLISHED CHROME  
CROMO SATINATO  
SATIN CHROME

# 896/45



## FINITURE/FINISHES

INOX BRASS  
INOX BRASS  
INOX CHROME  
INOX CHROME  
OTTONE LUCIDO VERNICIATO  
POLISHED BRASS  
OTTONE SATINATO VERNICIATO  
SATIN BRASS  
CROMO LUCIDO  
POLISHED CHROME  
CROMO SATINATO  
SATIN CHROME  
NICKEL SATINATO  
SATIN NICKEL

NOTTOLINO WC CON ROSETTA  
Ø 45 mm  
THUMBTURN WITH ROSE Ø 45 mm



# 896/50 I



## FINITURE/FINISHES

INOX BRASS  
INOX BRASS  
INOX CHROME  
INOX CHROME  
OTTONE LUCIDO VERNICIATO  
POLISHED BRASS  
OTTONE SATINATO VERNICIATO  
SATIN BRASS  
CROMO LUCIDO  
POLISHED CHROME  
CROMO SATINATO  
SATIN CHROME  
NICKEL SATINATO  
SATIN NICKEL  
ANTICO OPACO  
MATT ANTIQUE BRASS

NOTTOLINO WC CON ROSETTA  
Ø 50 mm  
THUMBTURN WITH ROSE Ø 50 mm



# 896/50 RT



## FINITURE/FINISHES

INOX BRASS  
INOX BRASS  
CROMO LUCIDO  
POLISHED CHROME  
CROMO SATINATO  
SATIN CHROME  
NICKEL SATINATO  
SATIN NICKEL  
LONDON NIGHT LUCIDO  
LONDON NIGHT POLISHED  
LONDON NIGHT SATINATO  
LONDON NIGHT SATIN  
RED COPPER LUCIDO  
RED COPPER POLISHED  
RED COPPER SATINATO  
RED COPPER SATIN  
GREY STONE  
GREY STONE  
ANTRACITE  
ANTRACITE

NOTTOLINO WC CON ROSETTA  
Ø 50 mm  
THUMBTURN WITH ROSE Ø 50 mm

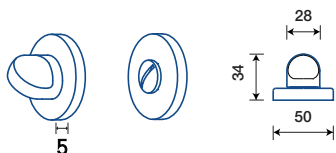

# 896/50 R



## FINITURE/FINISHES

INOX BRASS  
INOX BRASS  
OTTONE LUCIDO VERNICIATO  
POLISHED BRASS  
CROMO LUCIDO  
POLISHED CHROME  
CROMO SATINATO  
SATIN CHROME  
NICKEL SATINATO  
SATIN NICKEL  
ANTICATO  
ANTICATO  
BLACK IRON  
BLACK IRON

NOTTOLINO WC CON ROSETTA  
Ø 50 mm  
THUMBTURN WITH ROSE Ø 50 mm





# 896/K 52

NOTTOLINO WC CON ROSETTA  
Ø 52 mm  
THUMBTURN WITH ROSE Ø 52 mm



## FINITURE/FINISHES

ACCIAIO LUCIDO  
POLISHED STAINLESS STEEL  
ACCIAIO SATINATO  
SATIN STAINLESS STEEL

# 895/50 Q



## FINITURE/FINISHES

CROMO LUCIDO / POLISHED CHROME  
CROMO SATINATO / SATIN CHROME  
NICKEL SATINATO / SATIN NICKEL  
BIANCO / WHITE  
BRONZO TREND / BRONZE TREND  
LONDON NIGHT LUCIDO  
LONDON NIGHT POLISHED  
LONDON NIGHT SATINATO  
LONDON NIGHT SATIN  
RED COPPER LUCIDO  
RED COPPER POLISHED  
RED COPPER SATINATO  
RED COPPER SATIN  
GREY STONE / GREY STONE  
NERO OPACO / BLACK MATT  
CORTEN / CORTEN  
CRACKLÉ / CRACKLÉ  
OSSIDATO / OSSIDATO  
LEATHER / LEATHER

NOTTOLINO WC CON ROSETTA  
QUADRATA  
THUMBTURN WITH SQUARE ROSE

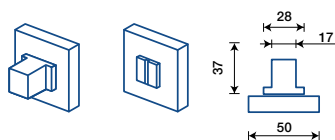



# 895/50 QT



## FINITURE/FINISHES

CROMO LUCIDO  
POLISHED CHROME  
CROMO SATINATO  
SATIN CHROME  
NICKEL SATINATO  
SATIN NICKEL  
BIANCO  
WHITE  
NERO OPACO  
BLACK MATT  
ANTRACITE  
ANTRACITE

NOTTOLINO WC CON ROSETTA  
BASSA QUADRATA  
THUMBTURN WITH THIN SQUARE  
ROSE

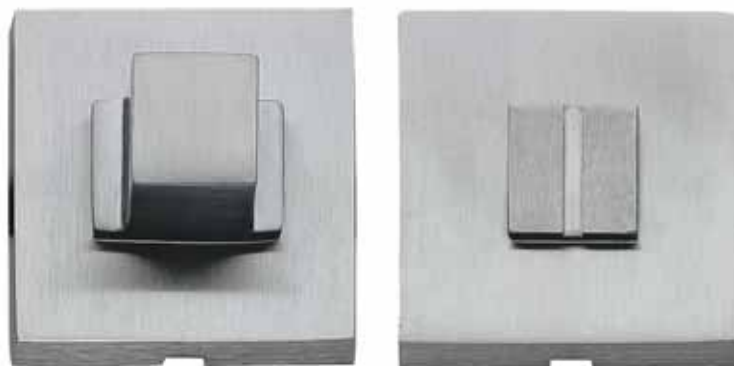
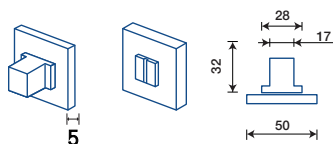

# 895/51 Q

## FINITURE/FINISHES

ACCIAIO LUCIDO  
POLISHED STAINLESS STEEL  
ACCIAIO SATINATO  
SATIN STAINLESS STEEL  
CROMO LUCIDO  
POLISHED CHROME  
CROMO SATINATO  
SATIN CHROME

NOTTOLINO WC CON ROSETTA  
QUADRATA  
THUMBTURN WITH SQUARE  
ROSE

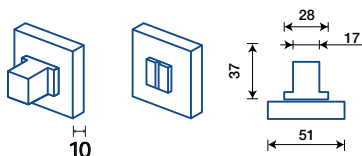

# 896/50 QR

NOTTOLINO WC CON ROSETTA  
QUADRATA CON ANGOLI  
RAGGIATI  
THUMBTURN WITH RADIUS  
SQUARE ROSE

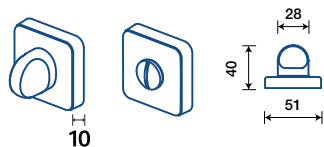

## FINITURE/FINISHES

CROMO LUCIDO  
POLISHED CHROME  
CROMO SATINATO  
SATIN CHROME

# 45

BOCCHETTA Ø 45 mm  
ESCUTCHEON Ø 45 mm

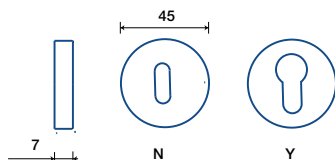

## FINITURE/FINISHES

INOX BRASS  
INOX BRASS  
INOX CHROME  
INOX CHROME  
OTTONE LUCIDO VERNICIATO  
POLISHED BRASS  
OTTONE SATINATO VERNICIATO  
SATIN BRASS  
CROMO LUCIDO  
POLISHED CHROME  
CROMO SATINATO  
SATIN CHROME  
NICKEL SATINATO  
SATIN NICKEL

# 50 I

BOCCHETTA Ø 50 mm  
ESCUTCHEON Ø 50 mm

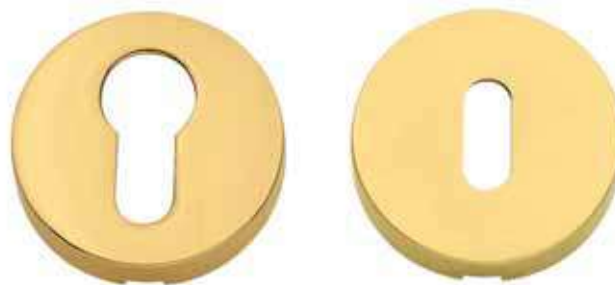
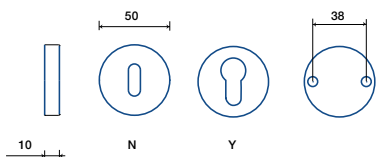

## FINITURE/FINISHES

INOX BRASS  
INOX BRASS  
INOX CHROME  
INOX CHROME  
OTTONE LUCIDO VERNICIATO  
POLISHED BRASS  
OTTONE SATINATO VERNICIATO  
SATIN BRASS  
CROMO LUCIDO  
POLISHED CHROME  
CROMO SATINATO  
SATIN CHROME  
NICKEL SATINATO  
SATIN NICKEL  
ANTICO OPACO  
MATT ANTIQUE BRASS

# 50 RT

BOCCHETTA BASSA Ø 50 mm  
THIN ESCUTCHEON Ø 50 mm

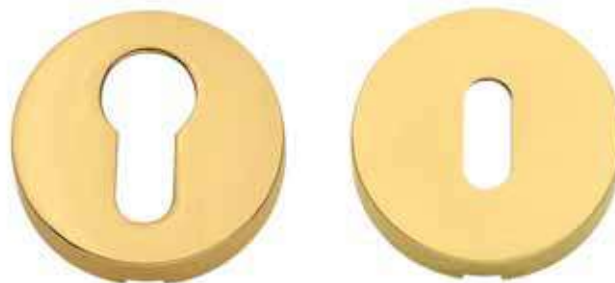
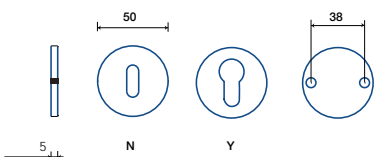

## FINITURE/FINISHES

INOX BRASS  
INOX BRASS  
CROMO LUCIDO  
POLISHED CHROME  
CROMO SATINATO  
SATIN CHROME  
NICKEL SATINATO  
SATIN NICKEL  
LONDON NIGHT LUCIDO  
LONDON NIGHT POLISHED  
LONDON NIGHT SATINATO  
LONDON NIGHT SATIN  
RED COPPER LUCIDO  
RED COPPER POLISHED  
RED COPPER SATINATO  
RED COPPER SATIN  
GREY STONE  
GREY STONE  
ANTRACITE  
ANTRACITE

# 50 R



## FINITURE/FINISHES

INOX BRASS  
INOX BRASS  
OTTONE LUCIDO VERNICIATO  
POLISHED BRASS  
CROMO LUCIDO  
POLISHED CHROME  
CROMO SATINATO  
SATIN CHROME  
NICKEL SATINATO  
SATIN NICKEL  
ANTICATO  
ANTICATO  
BLACK IRON  
BLACK IRON

BOCCHETTA Ø 50 mm  
ESCUTCHEON Ø 50 mm

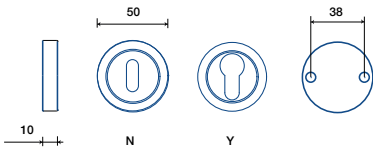

# K 52

## FINITURE/FINISHES

ACCIAIO LUCIDO  
POLISHED STAINLESS STEEL  
ACCIAIO SATINATO  
SATIN STAINLESS STEEL

BOCCHETTA Ø 52 mm  
ESCUTCHEON Ø 52 mm

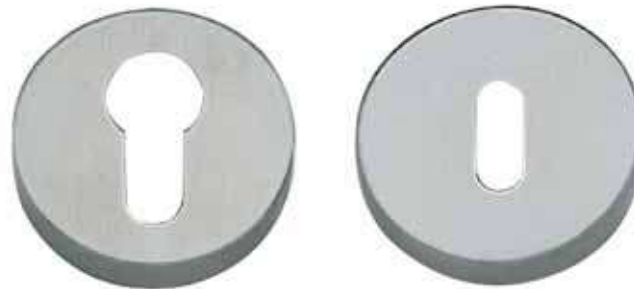
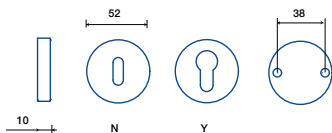

# 50 Q

BOCCHETTA QUADRATA  
SQUARE ESCUTCHEON

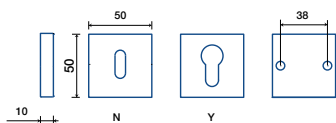

## FINITURE/FINISHES

CROMO LUCIDO / POLISHED CHROME  
CROMO SATINATO / SATIN CHROME  
NICKEL SATINATO / SATIN NICKEL  
BRONZO TREND / BRONZE TREND  
LONDON NIGHT LUCIDO  
LONDON NIGHT POLISHED  
LONDON NIGHT SATINATO  
LONDON NIGHT SATIN  
RED COPPER LUCIDO  
RED COPPER POLISHED  
RED COPPER SATINATO  
RED COPPER SATIN  
GREY STONE / GREY STONE  
BIANCO / WHITE  
NERO OPACO / BLACK MATT  
CORTEN / CORTEN  
CRACKLÉ / CRACKLÉ  
LEATHER / LEATHER  
OSSIDATO / OSSIDATO

# 50 QT

BOCCHETTA QUADRATA BASSA  
THIN SQUARE ESCUTCHEON

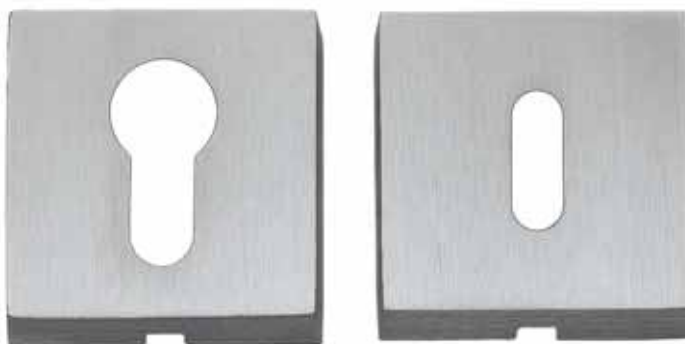
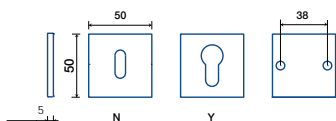

## FINITURE/FINISHES

CROMO LUCIDO  
POLISHED CHROME  
CROMO SATINATO  
SATIN CHROME  
NICKEL SATINATO  
SATIN NICKEL  
BRONZO TREND  
BRONZE TREND  
BIANCO  
WHITE  
NERO OPACO  
BLACK MATT  
ANTRACITE  
ANTRACITE

# 51 Q

BOCCHETTA QUADRATA  
SQUARE ESCUTCHEON

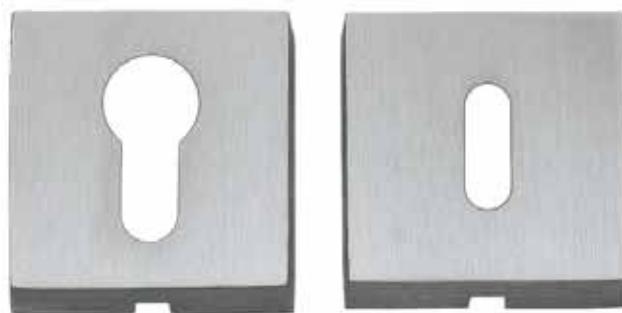
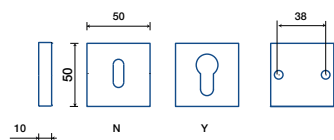

## FINITURE/FINISHES

ACCIAIO LUCIDO  
POLISHED STAINLESS STEEL  
ACCIAIO SATINATO  
SATIN STAINLESS STEEL  
CROMO LUCIDO  
POLISHED CHROME  
CROMO SATINATO  
SATIN CHROME

# 50 QR

BOCCHETTA QUADRATA CON  
ANGOLI RAGGIATI  
RADIUS SQUARE ESCUTCHEON

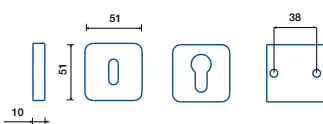

## FINITURE/FINISHES

CROMO LUCIDO  
POLISHED CHROME  
CROMO SATINATO  
SATIN CHROME

# 32 PO



BOCCHETTA OVALE  
OVAL ESCUTCHEON

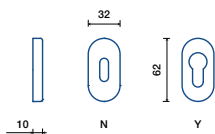

## FINITURE/FINISHES

INOX BRASS  
INOX BRASS  
INOX CHROME  
INOX CHROME  
OTTONE LUCIDO VERNICIATO  
POLISHED BRASS  
OTTONE SATINATO VERNICIATO  
SATIN BRASS  
CROMO LUCIDO  
POLISHED CHROME  
CROMO SATINATO  
SATIN CHROME  
NICKEL SATINATO  
SATIN NICKEL  
ANTICO OPACO  
MATT ANTIQUE BRASS  
ANTRACITE  
ANTRACITE

# 31 Q



BOCCHETTA RETTANGOLARE  
RECTANGULAR ESCUTCHEON

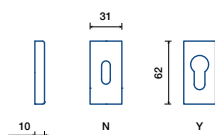

## FINITURE/FINISHES

ACCIAIO SATINATO  
SATIN STAINLESS STEEL  
OTTONE LUCIDO VERNICIATO  
POLISHED BRASS  
OTTONE SATINATO VERNICIATO  
SATIN BRASS  
CROMO LUCIDO  
POLISHED CHROME  
CROMO SATINATO  
SATIN CHROME  
NICKEL SATINATO  
SATIN NICKEL  
ANTRACITE  
ANTRACITE

# Fermaporte 540

## Door-stop

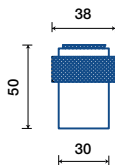

### FINITURE/FINISHES

OTTONE LUCIDO VERNICIATO  
 POLISHED BRASS  
 CROMO LUCIDO  
 POLISHED CHROME  
 CROMO SATINATO  
 SATIN CHROME  
 ANTRACITE  
 ANTRACITE

# Fermaporte 541

## Door-stop

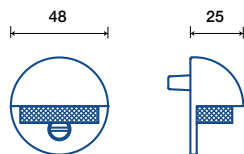

### FINITURE/FINISHES

OTTONE LUCIDO VERNICIATO  
 POLISHED BRASS  
 CROMO LUCIDO  
 POLISHED CHROME  
 CROMO SATINATO  
 SATIN CHROME

# Chiave 510

## Key

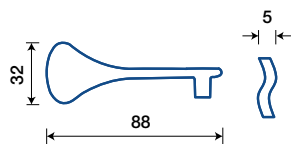

### FINITURE/FINISHES

INOX BRASS  
 INOX BRASS  
 OTTONE LUCIDO VERNICIATO  
 POLISHED BRASS  
 CROMO LUCIDO  
 POLISHED CHROME  
 CROMO SATINATO  
 SATIN CHROME



# Set per porte blindate Easy

## Kit for security door

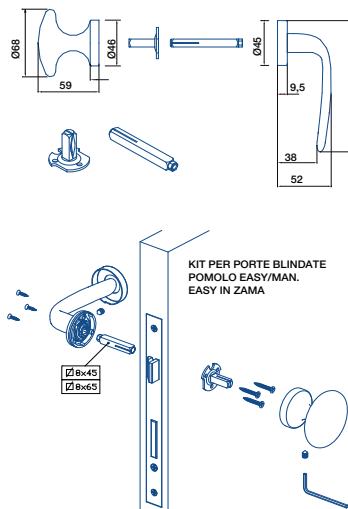

### FINITURE/FINISHES

INOX BRASS  
INOX BRASS  
CROMO LUCIDO  
POLISHED CHROME  
CROMO SATINATO  
SATIN CHROME

# 400 DK

MECCANISMO CON CILINDRO  
E CHIAVE

MECHANISM WITH CYLINDER  
AND KEY

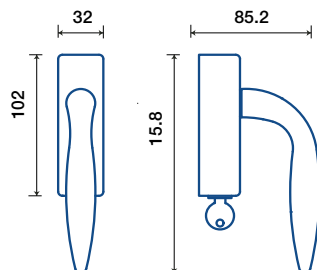

### FINITURE/FINISHES

INOX BRASS  
INOX BRASS  
INOX CHROME  
INOX CHROME  
OTTONE LUCIDO VERNICIATO  
POLISHED BRASS  
CROMO LUCIDO  
POLISHED CHROME  
CROMO SATINATO  
SATIN CHROME

# Movimenti per finestra / Window mechanism

## A MOVIMENTO DK-CP

DK MECHANISM WITH PINS



## B MOVIMENTO DK RASATO

DK MECHANISM WITHOUT PINS



## C MOVIMENTO CREMONESE

WINDOWS MECHANISM FOR PLATE



## D MOVIMENTO CREMONESE

WINDOWS MECHANISM FOR PLATE



## E MOVIMENTO CREMONESE

WINDOWS MECHANISM FOR PLATE



**MOVIMENTO CREMONESE  
ECONOMICO PER PIASTRINA  
CON FORI ART 30 F GRATZ CON  
BOCCOLE +Q 7**

WINDOWS MECHANISM FOR  
PLATE ART 30F GRATZ WITH  
BUSHES + 7mm SPINDLE

**MOVIMENTO CREMONESE  
ECONOMICO PER PIASTRINA  
CON FORI ART 30 F GRATZ CON  
PERNI**

WINDOWS MECHANISM FOR  
PLATE ART 30F GRATZ WITH PINS

**MOVIMENTO CREMONESE  
ECONOMICO PER PIASTRINA  
CON FORI ART 30 F GRATZ CON  
BOCCOLE**

WINDOWS MECHANISM FOR  
PLATE ART 30F GRATZ WITH  
BUSHES

#### F MOVIMENTO CREMONESE

WINDOWS MECHANISM FOR PLATE



**MOVIMENTO CREMONESE  
LUSSO PER PIASTRINA SENZA  
FORI ART 30 MARTELLINA Q 7**  
WINDOWS MECHANISM FOR PLATE  
ART 30 + 7mm SPINDLE

#### G MOVIMENTO CREMONESE

WINDOWS MECHANISM FOR PLATE



**MOVIMENTO CREMONESE  
LUSSO PER PIASTRINA SENZA  
FORI ART 30 GRATZ CON BOCCOLE**  
WINDOWS MECHANISM FOR PLATE  
ART 30 GRATZ WITH BUSHES + 7 mm  
SPINDLE

#### H MOVIMENTO CREMONESE

WINDOWS MECHANISM FOR PLATE



**MOVIMENTO CREMONESE  
LUSSO PER PIASTRINA SENZA  
FORI ART 30 GRATZ CON PERNI**  
WINDOWS MECHANISM FOR PLATE  
ART 30F GRATZ WITH PINS

#### I MOVIMENTO CREMONESE

WINDOWS MECHANISM FOR PLATE



**MOVIMENTO CREMONESE  
LUSSO PER PIASTRINA SENZA  
FORI ART 30 GRATZ CON BOCCOLE**  
WINDOWS MECHANISM FOR PLATE  
ART 30 GRATZ WITH BUSHES

## Base per pomolo fisso / Dummy base system

#### BASE PER POMOLO FISSO

FIXED KNOB BASE

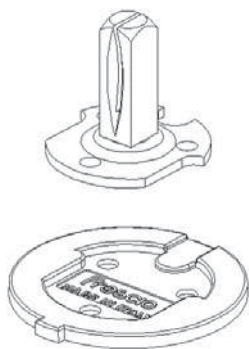

**BASE PER POMOLO FISSO  
PER ROSETTA 50I-50R-50Q-50QR**  
FIXED KNOB BASE FOR ROSES  
50I-50R-50Q-50QR

# Espositori/Displays

ESPOSITORE COMPONIBILE / PLEXIGLASS ESTRAIBILI

MODULAR DISPLAY / EXTRACTABLE PLEXIGLASS

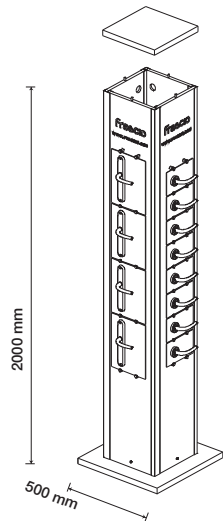

ESPOSITORE DA PARETE / PLEXIGLASS ESTRAIBILI

WALL DISPLAY / EXTRACTABLE PLEXIGLASS

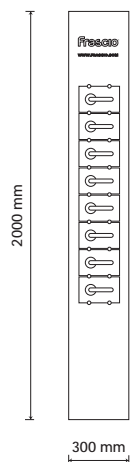

**Frascio** s.r.l.

Via Nazionale 6  
25074 Lavenone (BS) Italia

Tel. +39 0365 839001

Fax. +39 0365 83578

e-mail: [info@frascio.it](mailto:info@frascio.it)

[www.frascio.com](http://www.frascio.com)